

**PROFIBUS Interface Option
for the HI 2151 Series
Weight Controller**

**OPERATION AND
INSTALLATION
MANUAL**

Document Part Number 0596-0231-01 Revision E

**HI 2151 Series Weight Controller
Profibus Interface Option**

Table of Contents

SECTION 1	OVERVIEW	1
1.1.	Scope	1
1.2.	Description	1
1.3.	Function	1
1.4.	Specifications	1
1.5.	PROFIBUS-DP Capabilities	2
1.5.3	Data Exchange	2
1.5.4	Diagnostics	2
1.5.5	Baud Rate Auto-Detect	3
1.5.6	Multiple Nodes	3
1.5.7	GSD File	3
1.5.8	Type File	3
1.6	Performance Characteristics	3
SECTION 2	INSTALLATION	5
2.1.	Scope	5
2.2	Unpacking	5
2.3	Installing the Profibus Interface Option Card	5
2.4.	Connecting the Network Cable to the Card	8
2.5.	Cable and Connector Requirements	9
2.6	Cable Pin Definitions	9
2.7	Communication Rate/Cable Lengths/Connectors	10
SECTION 3	SETUP	11
3.1	Scope	11
3.2	Panel, Wall and Remote Setup Procedure	11
3.3	Blind Unit Setup Procedure	13
3.3.1	Setting the Address for Blind Units	14
SECTION 4	BLOCK READS	15
4.1.	Scope	15
4.2.	Transfer Commands	15
4.2.1	Overview of Transfer Commands	15
4.2.2	Overview of Block Transfer Commands	15
4.3	Detailed Command Set For Block Reads	16
4.4	Response/Error Code Setup	16
4.5	Block Read Command Setup	17
4.6	Block Read Example	17
4.7	Set Point Status/Description Bytes	18

**HI 2151 Series Weight Controller
Profibus Interface Option**

4.7.1	Set point Status.....	18
4.7.2	Set point Description.....	18
4.8	Block Read Data Numbers.....	19
SECTION 5 BLOCK WRITES		27
5.1	Scope 27	
5.2	Overview of Transfer Commands	27
5.3	Overview of Block Transfer Commands	27
5.4	Detailed Command Set for Block Transfer (Writes).....	28
5.5	Block Write Example	28
5.6	Block Write Command Numbers.....	29
SECTION 6 SELECTABLE READS.....		36
6.1	Scope 36	
6.2	Overview of Transfer Commands	36
6.3	Overview of Selectable Transfer Commands	36
6.4	Detailed Data Set for Selectable Read(S)	37
6.5	Selectable Read Command Setup Procedures	37
6.6	Selectable Read Command Example	38
6.7	Selectable Read Data	39
6.7.1	Full Status and Weight Data	39
6.7.2	Floating Point Weight Data	40
6.7.3	Set point Relay Status 1-8	40
6.7.4	Read Tare Value.....	41
6.7.5	Calibration Parameters	41
6.7.6	Sticker Value (Not valid for the HI 2151/30WC)	42
6.7.7	Configuration of Rate-of-Change.....	42
6.7.8	Configuration of Analog Output	42
6.7.9	Configuration of Standard RS232 Port	42
6.7.10	Instrument ID	43
6.7.11	Instrument identification.....	43
6.7.12	Response/Error Code	43
6.7.13	Integrated Technician (Not Valid for HI 2151/20WC)	44
SECTION 7 SELECTABLE WRITES		45
7.1	Scope	45
7.2	Overview of Transfer Commands	45
7.3	Overview of Selectable Transfer Commands	45
7.4	Detailed Command Set for Selectable Writes.....	46
7.5	Selectable Write Command Setup Procedures	46
7.6	Operator Selectable Write Example.....	47
7.7	Selectable Write Commands.....	48
7.7.1	Set Point Relay Functions	48
7.7.2	Send Tare Value.....	49
7.7.3	Scale Calibration Parameters	49

Table of Contents

7.7.4	Sticker Value (This data is not valid for the HI 2151/30WC)	49
7.7.5	Configuration of Rate-of-Change.....	49
7.7.6	Configuration of Analog Output	50
7.7.7	Configuration of Standard RS232 Port	50
7.7.8	WAVERSAVER & Excitation Monitor (HI 2151/30WC Only).....	50
SECTION 8	TROUBLESHOOTING PROCEDURES	51
8.1.	Scope	51
8.2	Disassembly and Reassembly Notes and Cautions	51
8.3	TroubleShooting Guide	52
8.3.1	LED Does Not Come ON (See Fig. 8-1).....	52
8.3.2	Self Test Fails	52
8.4	Error Codes	53
8.4	Clearing Profibus Diagnostic Code Associated Bit(S)	55
8.5	PROFIBUS Status Indicators	56
8.5.1	PROFIBUS Interface Card LED.....	56
8.5.2	HI 2151 Series Indicator Light	56
APPENDIX A	- IEEE FOR NORMAL FLOAT TYPE	57
APPENDIX B	- DECIMAL, HEX, OCTAL, AND BINARY CONVERSION CHART.....	58

Section 1 OVERVIEW

1.1. SCOPE

This manual describes the operating procedures, specifications, installation, and setup for the Hardy Process Solutions, PROFIBUS Interface Option -B12, which is used with the Hardy HI 2151 Series Weight Controllers.

To ensure the maximum service life and safe operation of the PROFIBUS Interface Card, use the card only as described in this manual and observe the cautions, warnings, and safety procedures.

Hardy Process Solutions appreciates your business. Should you have any problems, please contact our Customer Service Department at:

Phone: (858) 278-2900 **FAX:** (858) 278-6700

1.2. DESCRIPTION

Using the Siemens SPC3 chip set, the PROFIBUS Option B12 interface card serves as a high speed, intelligent client to a scanning PROFIBUS-compatible server that is setup on a PC or PLC (Programmable Logic Controller). This arrangement supports PROFIBUS-DP (Decentralized Periphery) and allows users to access data exchanged between the server and the HI 2151 Weight Controller for use in PLC ladder logic, chart, or other programs.

You can configure the HI 2151 Series-B12 to function as either a local display for weighing parameters or a blind controller that digitizes load cell signals and provides responsive set point control.

1.3. FUNCTION

The PROFIBUS Interface Option allows the PROFIBUS server to use all of the Hardy HI 2151/20WC configuration, weighing, and scale-calibration functions. The interface provides bi-directional communications between a server and client and allows the server to access all configuration and weighing parameters of the HI 2151 Series Weight Controllers.

Two data transfer options let you select commands and summaries: Selectable Transfers or Block Transfers (a set of pre-defined data blocks). The Write commands (outputs) are sent from the server to the weight controller. The Read Data Summaries (inputs) return weight and scale status data to the server.

Passing the data in integer format eliminates conversion steps and reduces the time needed to incorporate the PROFIBUS Interface Option into the server's ladder logic or chart code. The Interface uses transmission medium (2 or 4 wire cable) characteristic of serial field bus applications.

1.4. SPECIFICATIONS

The PROFIBUS Interface Option is used for the following applications:

- Batching/Blending
- Check Weighing
- Filling/Dispensing
- Force Measurement
- Level by Weight
- Rate Monitoring

1.5. PROFIBUS-DP CAPABILITIES

1.5.1 Watch Dog

Watch Dog communication control detects failures in the bus or the assigned DPM1 (DP-Master - Class 1, which is the central controller in PROFIBUS-DP). If the interface card detects no successful data transfers within a set interval, it switches its outputs to the fail-safe state until successful communication is resumed.

1.5.2 Configuration

Configuration data contains the range of input and output areas and the information about the data consistency (byte or word length).

The default configuration for Hardy PROFIBUS Interface is 16 words or 32 bytes.

For the 32 byte I/O the identifier bytes have the following format:

Number of Configuration bytes: 2

- Config byte 1 77 (hexadecimal)
- Config byte 2 77 (hexadecimal)

The maximum number of bytes of I/O can be achieved by setting:

Number of Configuration bytes: 4

- Config byte 1 7D (Hex)
- Config byte 2 7D (Hex)
- Config byte 3 7D (Hex)
- Config byte 4 7D (Hex)

For 112 bytes of input and 112 bytes of output.

 **NOTE:** See DIN Standard 19245, Part 3, Paragraph 8.3.5, page 55, for a description of the config data.

1.5.3 DATA EXCHANGE

The PROFIBUS Interface Option can exchange the Input (Read) and Output (Write) data between devices. The PROFIBUS inputs and outputs are either selectable or block reads. The PROFIBUS Interface Option supports the standard 16-word or 32-byte format for transfers, but you can set it to any buffer size that is less than or equal to 112 bytes.

PRE-DEFINED BLOCKS ARE UP TO 32 BYTES IN LENGTH. IF LESS THAN 32 BYTES ARE DESIRED FOR BUS TRAFFIC CONSIDERATIONS, THEN SELECTABLE TRANSFERS SHOULD BE USED.

 **NOTE:** Two bytes equal one word.

1.5.4 DIAGNOSTICS

The PROFIBUS Interface Option has built-in diagnostics. Write command errors set diagnostic bits, e.g. the NACK (not acknowledge) bit.

1.5.5 BAUD RATE AUTO-DETECT

The PROFIBUS network can support up to 12 Mbaud transfer rates. The server's Auto - Detect function finds the system baud rate (the rate of the slowest component), which eliminates the need for board settings.

1.5.6 MULTIPLE NODES

Depending on the PLC, the PROFIBUS network is configurable to include several nodes (The HI 2151 weight controller is one node) up to a maximum of 126.

1.5.7 GSD FILE

Some PLC's require the GSD file (HRDY2151.GSD) to assist in setting up the HI 2151/20WC Weight Controller on the PROFIBUS network. See your PLC O&M manual or the Hardy web site. To get the GSD file file from the Hardy Website:

1. Select Support
2. Highlight Online Support
3. Click on Sample Programs.
4. Select it from the GSD pull-down list.

1.5.8 TYPE FILE

Six Type files, referred to as the Device Data Base (DDB) Files, may be needed to configure some of the Siemens PLCs. They are included on the Hardy disk (See DIN Standard 19245, Part 3, Paragraph 13, Page 197) Refer to the specific Siemens PLC manual for instructions. If type files are needed for older model PLCs, contact Hardy Tech Support.

Description for the use of the type files:

- Window COM: Copy the attached type file HI2151ax.200 in the directory s:\COMWINx0\TYPEDAT5x. After starting WIN COM you can select your device in the family "Others".
- DOS Com V4.x: Copy the attached files depending on your selected language with the DOS Com under the directory of the Com.

HI2151TE.200 - English Version

HI2151TD.200 - German Version

HI2151TF.200 - French Version

HI2151TI.200 - Italian Version

HI2151TS.200 - Spanish Version

1.6 PERFORMANCE CHARACTERISTICS

Environmental Requirements

1. Temperature:
 - Operating - 10° to 50° C (14° to 122° F)
 - Storage - 20° to 85° C (-4° to 185° F)

**HI 2151 Series Weight Controller
Profibus Interface Option**

2. Humidity:

0 to 80% Relative Humidity (Non-condensing)

Baud Rate

9,600 kbaud to 12 Mbaud - (Auto-Selectable)

Process Control Standards Reference

Process Fieldbus (PROFIBUS) - DIN 19 245

Reference Data Protocols

Master manuals will reference data either in bytes or words using the different protocols that are particular to a server or series of servers. For example:

1. The Siemens TI 505 Series of PLCs use the Motorola protocol and expresses reference data in bytes.
2. The Siemens S5 and S7 PLC series and the Allen-Bradley PLC5 PLC series use an Intel protocol and express reference data in words.
3. The PROFIBUS manual references both bytes and words.

This means that the Least Significant Byte (LSB) and the Most Significant Byte (MSB) locations vary. Note that two bytes equals one word. (See the charts below)

Siemens TI 505 or others using (Motorola) Protocol (Bytes)															
One Word (Expressed in Bytes)															
Least Significant Byte (LSB)								Most Significant Byte (MSB)							
7	6	5	4	3	2	1	0	7	6	5	4	3	2	1	0

Siemens S5 and S7 & Allen-Bradley PLC5 PLC series or others using (Intel) Protocol (Bytes)															
One Word (Expressed in Words)															
Most Significant Byte (MSB)								Least Significant Byte (LSB)							
7	6	5	4	3	2	1	0	7	6	5	4	3	2	1	0

TABLE 1-1 REFERENCE DATA PROTOCOLS

SECTION 2 INSTALLATION

2.1. SCOPE

Chapter 2 explains unpacking, cabling and interconnection, and installation of the -B12 PROFIBUS Interface Card. Operators and maintenance personnel should read the procedures in this chapter before installing or operating the PROFIBUS interface card.

2.2 UNPACKING

1. Inspect the packing for damage of any kind, before signing for or opening the package.
2. Report any damage to the carrier company immediately.
3. Check to see that everything in the package matches the bill of lading. You should normally have:

Purchased with a new Weight controller

- 1 - HI 2151-B12 Series Weight Controller + PROFIBUS Interface Option.
- 1 - HI 2151 Series Operation & Installation Manual
- 1 - PROFIBUS Operation & Installation Manual
- 1 - CD with the GSD File and Type Files.

Purchased separately to retrofit an HI 2151 Series WC:

- 1 - HI-2151 Series-B12 PROFIBUS Interface (PCB)



NOTE:

The PROFIBUS Interface PCB is completely interchangeable between HI-2151 Series Weight Controllers.

- 4 - #4 Phillips pan head, SEM Machine Screws.
 - 1 - PROFIBUS Operation & Installation Manual
 - 1 - CD with the GSD File and Type Files.
 - Configuration Instructions - Prt. #0597-0428-01
4. Record the model number and serial number of the weight controller or interface card and EPROM version. Store this information in a convenient, secure location for reference when buying parts or firmware upgrades.

2.3 INSTALLING THE PROFIBUS INTERFACE OPTION CARD

1. Disconnect all power cords from the HI 2151 Series Weight Controller.



NEVER INSTALL OR REMOVE THE PROFIBUS INTERFACE CARD WITH THE POWER CORD CONNECTED.

2. Accessing the printed circuit boards
 - A. Wall Mount Installation (NEMA 4x Enclosure)
 - Open the front panel of the NEMA enclosure.
 - A/D converter PCB and Power/Relay PCB are fastened to the rear panel.

HI 2151 Series Weight Controller Profibus Interface Option

B. Panel Mount, Remote, and Blind Installations.

- Remove the four Phillips head machine screws that fasten the chassis to the HI 2151 Series WC cover.

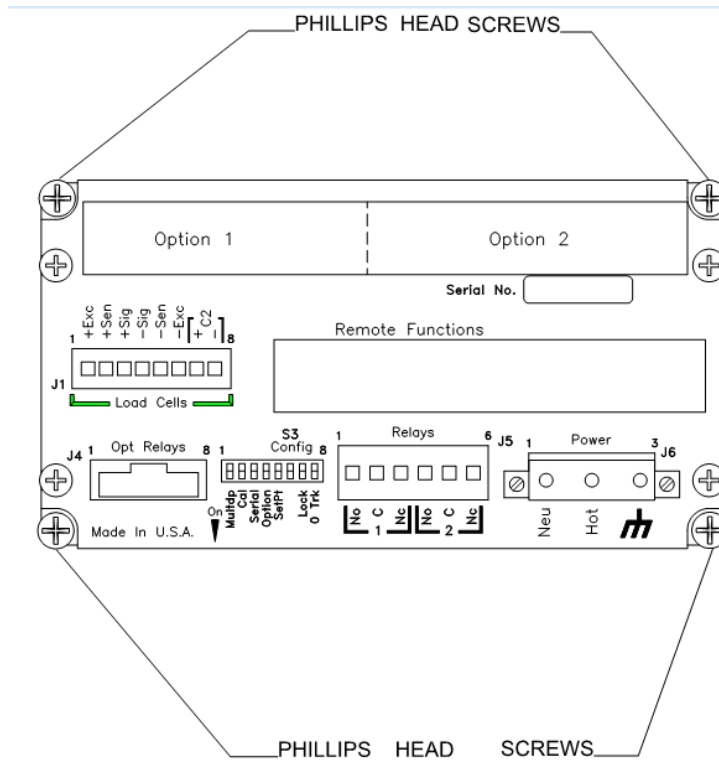

Figure 2-2

- Pull the chassis completely out of the cover.
- Place the chassis on an anti-static pad.
- Put on an anti-static wristlet and connect it to the anti-static pad.
- Analog to Digital PCB is clearly visible and there are eight standoffs mounted on the board. (See Fig. 2-2)
- Remove the PROFIBUS Interface Card from the anti-static bag.

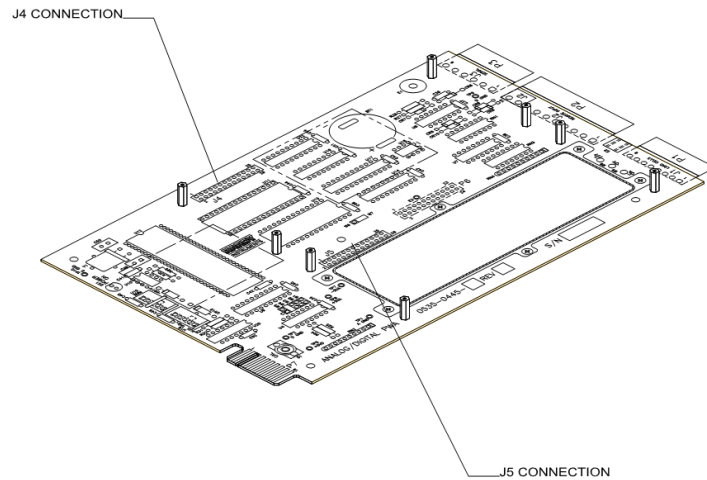

Figure 2-3

8. On the solder side of the PROFIBUS Interface Card, the side opposite the components, there is a pin connector. (See Fig. 2-3)

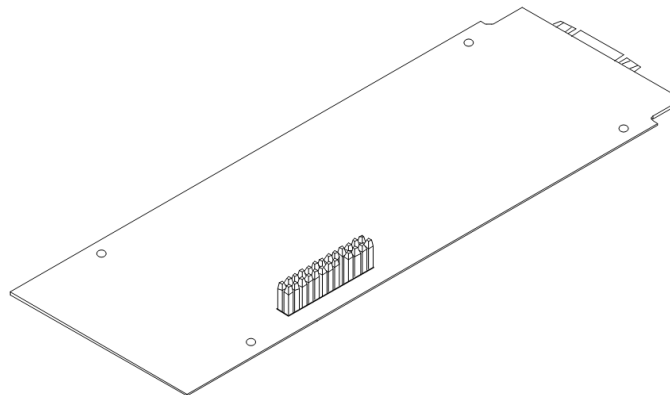

Figure 2-4

9. With the pin connector side down, carefully plug the PROFIBUS Interface Card into either connector J4 or J5 (See Fig. 2-2) whichever is available. These connectors also refer to option 1 or option 2 on the rear panel. Option 1 uses connector J5. Option 2 uses connector J4. (See Fig. 2-4)



MAKE SURE THAT ALL THE PINS ARE PLUGGED INTO THE J4 OR J5 CONNECTOR. FAILURE TO PROPERLY INSTALL THE PROFIBUS INTERFACE CARD WILL RESULT IN PERSONAL INJURY OR PROPERTY DAMAGE.

HI 2151 Series Weight Controller Profibus Interface Option

10. The through holes on the PROFIBUS Interface Card should line up with the threaded holes in the standoffs. A little adjustment is sometimes necessary to line them up. (See Fig. 2-5)

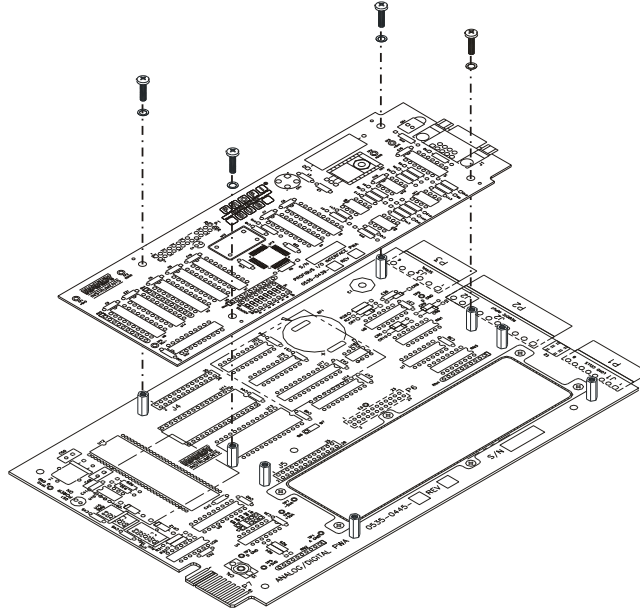



Figure 2-5

11. Place the washers over the holes on the component side of the PROFIBUS Interface Card and install the four Phillips pan head SEM screws (See Fig. 2-5).

 **NOTE:** For blind installations the dip switches will need to be set before reinstalling the chassis. (See Chapter 3, paragraph 3.2 for instructions)

12. Slide the chassis back into the HI 2151 Series WC cover.
13. Replace the four Phillips pan head SEM screws that fasten the chassis to the HI 2151 Series WC cover.

2.4. CONNECTING THE NETWORK CABLE TO THE CARD

1. The 9-pin female connector is located on the rear panel of the chassis. If the PROFIBUS Interface Card is plugged into slot J5 the 9-pin connector will be in Option Slot 1. If the PROFIBUS interface card is plugged into slot J4 the 9-pin connector will be in Option Slot 2.
2. Plug the Siemens cable assembly and bus connector into the 9-pin female connector on the rear panel of the chassis. (See Fig. 2-6)

 **NOTE:** If the weight controller is the last node on the bus, the terminating resistor must be ON.

 **NOTE:** It is highly recommended that the Siemens cable and bus connector listed be used. Check with your closest Siemens Electronics dealer for pricing and availability.

2.5. CABLE AND CONNECTOR REQUIREMENTS

- Siemens Bus Connector - (SINEC L2) Prt. # 6ES7-972-0BA20-OXAO
- Siemens Cable LWF, CMX 75C (shielded) - (SINEC L2) Prt. #6XV1-830-OAH10

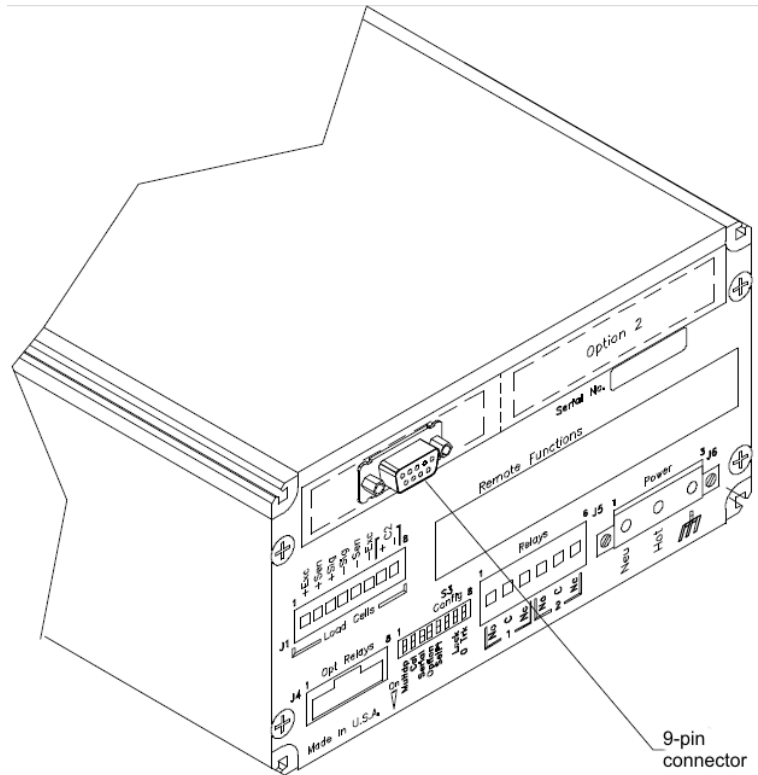

Figure 2-6

2.6 CABLE PIN DEFINITIONS

- Pin 1 - Ground (outer braided shield)
- Pin 3 - Signal "B" (Red)
- Pin 8 - Signal "A" (Green)

HI 2151 Series Weight Controller
Profibus Interface Option

2.7 COMMUNICATION RATE/CABLE LENGTHS/CONNECTORS

Shielded twisted pair two wire cable is required for the PROFIBUS Interface Connection. The characteristic impedance of the cable should be in the range between 135 and 165 Ohms (3 to 20 MHz), the cable capacity (conductor-conductor) should be <30 pF/M and the conductor area should be $\geq 0,34 \text{ mm}^2$. The 9 pin din connector on the option board is used for all PROFIBUS connections.

Transmission Speed	Without Repeater 32 Nodes	With 1 Repeater 64 Nodes	With 2 Repeaters 92 Nodes	With 3 Repeaters 122 Nodes
9.6 k	1200 m	2400 m	3600 m	4800 m
19.2 k	1200 m	2400 m	3600 m	4800 m
93.75 k	1200 m	2400 m	3600 m	4800 m
1875 k	600 m	1200 m	1800 m	2400 m
500 k	400 m	800 m	1200 m	1600 m
1.5 M	200 m	400 m	600 m	800 m
3,6,12 M	100 m	200 m	300 m	400 m

SECTION 3 SETUP

3.1 SCOPE

Chapter 3 consists of all the procedures to setup the PROFIBUS Interface Option. To make sure that the interface option works properly, programmers and maintenance personnel should be familiar with this chapter before setting up or operating the system.

3.2 PANEL, WALL AND REMOTE SETUP PROCEDURE

1. Press the 7/Option button. (See Fig. 3-1) The first option appears.

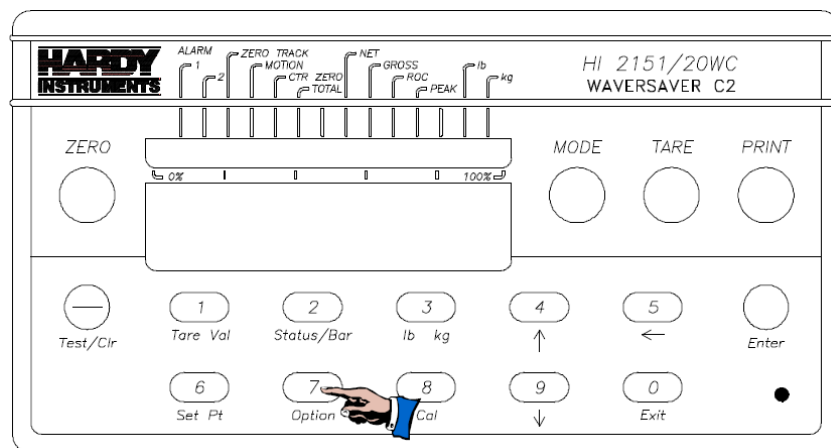



Figure 3-1

2. Press the “4/Up” (↑) arrow button until ProFi appears on the display. (See Fig. 3-2)
3. Press the “Enter” button. The current node station address appears.
4. Use the keypad to enter a node station address (the valid address range is 1-125). The station address must be a unique number for each node on the bus.
5. Press the “Enter” button to set the node station address.

 **NOTE:** *The PROFIBUS node address number is displayed in decimal on the weight controller.*

**HI 2151 Series Weight Controller
Profibus Interface Option**

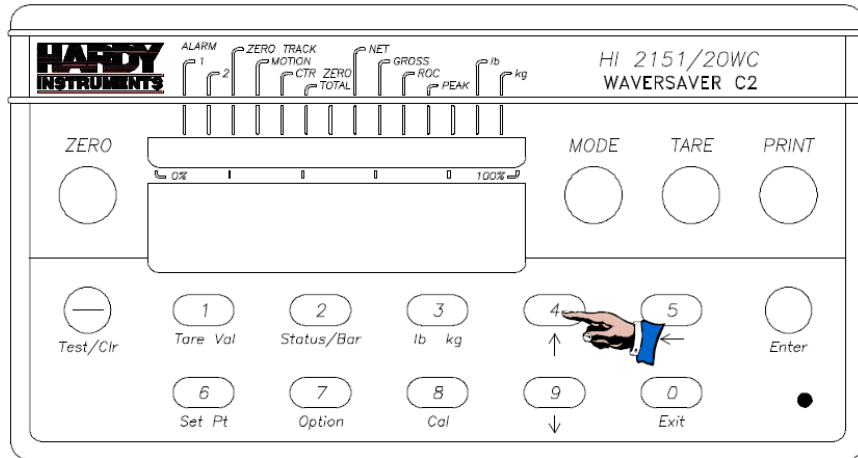

Figure 3-2

6. Press the Test/Clr button. The display should now show four “0’s”. (See Fig. 3-3)

NOTE: *On an uncleared display, numbers are added to the right of the existing number.*

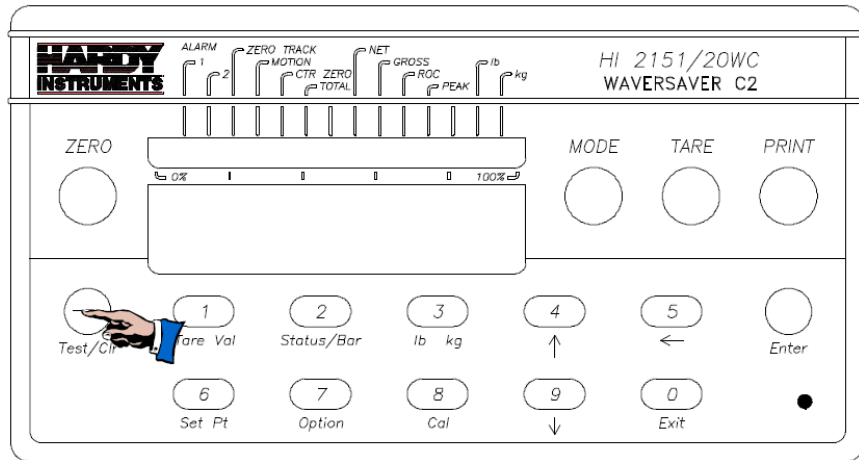

Figure 3-3

7. Use the keypad to enter the new number.
8. Press the “Enter” button to set the address.
9. Exit the Options Menu by pressing the “Exit” button.

NOTES:

1. *It may be necessary to configure the PLC (using manual or auto configuration) in addition to powering down and powering up the instrument to activate the new menu selections. See your PLC manual to determine if this is necessary*
2. *The PROFIBUS Station Address cannot be changed through the PROFIBUS Network.*
3. *The PROFIBUS node address number is displayed in decimal on the weight controller.*

3.3 BLIND UNIT SETUP PROCEDURE

A blind HI 2151 Series Weight Controller is configured without a front panel and keypad. To set the PROFIBUS station address, a dip switch on the PROFIBUS Interface Card and the Power & Relay PCB, must be set.

To set the power and relay (Prt # 0535-0427) dipswitches for the PROFIBUS Interface Card:

1. Disconnect the power cord.
2. Open the panel door.
3. On the Power & Relay Printed Circuit Board (Prt # 0535-0427) there is a dipswitch S2. (See Fig. 3-4)

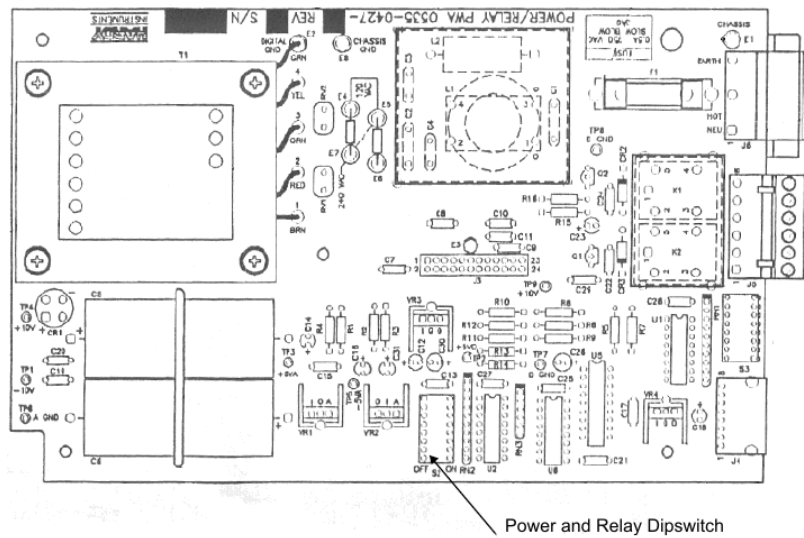

Figure 3-4

4. Set the #6 Dipswitch to “on” and the other switches to “off” (See Fig. 3-5)

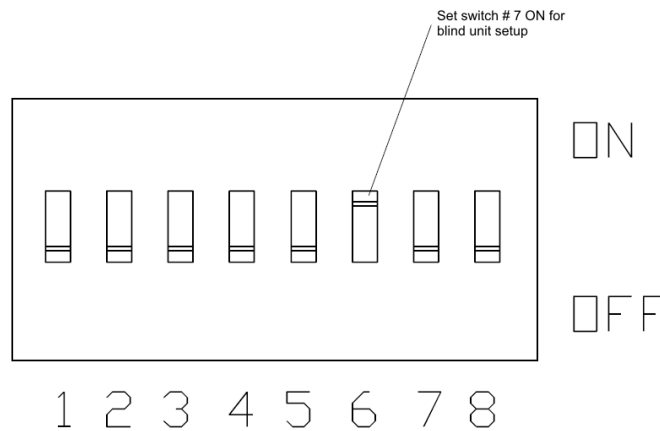

Figure3-5

HI 2151 Series Weight Controller Profibus Interface Option

3.3.1 SETTING THE ADDRESS FOR BLIND UNITS

1. The Dipswitches on the PROFIBUS Interface Card represent a binary value as follows:

<u>Switch</u>	<u>Binary Value</u>
1	1
2	2
3	4
4	8
5	16
6	32
7	64
8	Not used

2. A PROFIBUS address can have a binary value from 1 to 125.
3. To set the address move the dipswitches that total the address binary number to the “on” position. For example: Address 17 requires dip switches 5 (16) and 1 (1) to be turned “on”, and all the other switches must be turned “off”. (See Fig. 3-6)
4. After setting the address, the PLC can communicate with the Blind Weight Controller.

 **NOTE:** *The PROFIBUS Station Address cannot be changed through the PROFIBUS network.*

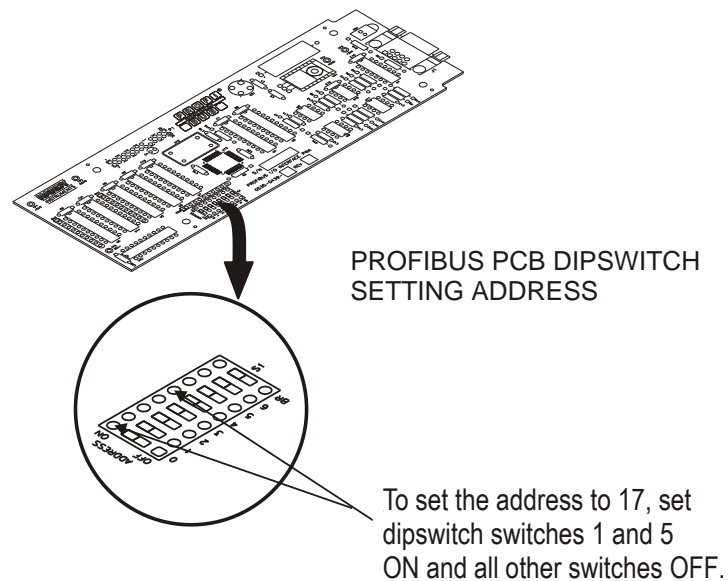



Figure 3-6

 **NOTE:** *For PROFIBUS Card Serial Numbers 1001 - 1050, the dipswitch numbers do not match the silk screened numbers on the circuit board. To set an address of 17 on the dipswitch turn on 1 & 5, which correspond to the silk screened numbers 0 & 4.*

SECTION 4 BLOCK READS

4.1. SCOPE

Chapter 4 covers block read commands for the PROFIBUS Interface Option. Programmers and users should be familiar with this chapter before operating the PROFIBUS Interface Option.

4.2. TRANSFER COMMANDS

4.2.1 OVERVIEW OF TRANSFER COMMANDS

1. PROFIBUS Interface Card maximum buffer size: 112 byte
2. Siemens PLC

TI 505 Series PLCs

- Requires the Field Interface Module (FIM) to communicate over PROFIBUS.
- Can continually exchange up to 32 words or 64 bytes for both PLC input and output with each client device.

S5 Series PLCs

- Requires IM 308C Module to communicate over PROFIBUS.
- Can continually exchange up to 244 bytes for PLC input and output with each client device.

S7 Series PLC

- PROFIBUS ready, does not require additional modules.
- Can continually exchange up to 244 bytes for PLC input and output with each client device.

3. Allen-Bradley PLC5 Series

- Requires PROFIBUS DP module to communicate over PROFIBUS.
- Can continually exchange up to 244 bytes for both PLC Input and Output with each client device.

4.2.2 OVERVIEW OF BLOCK TRANSFER COMMANDS

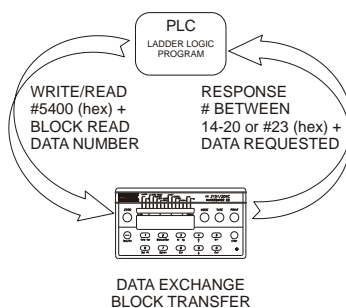

1. The PLC server determines the amount of bytes that can be transferred; not the PROFIBUS interface option.
2. When using the HI 2151 Series PROFIBUS interface, the user can select the Block Read Data Summaries and Block Write Commands as required. However, the amount of bytes that can be transferred is dependent on the data transfer capability of the server being used.
3. The ladder logic program provides the server with the ability to read and write weight data by referencing the PROFIBUS address, the byte numbers and number of bytes.

HI 2151 Series Weight Controller Profibus Interface Option

 NOTE: *The decimal point is not included in values transferred. The decimal position is a separate parameter.*

4.3 DETAILED COMMAND SET FOR BLOCK READS

 NOTE: *We recommend that front panel functions be controlled through the PROFIBUS network and that the front panel control be disabled or locked out. (See the HI 2151 Series Weight Controller Operation and Installation Manual for lockout instructions)*

1. The Block Read data to be input to the server is always initiated by a Block Write Command designating the block number that the HI 2151/20WC Weight Controller will send to the server.

 NOTE: *If your server Device **does not** have built in PROFIBUS diagnostic capability set up the Response/Error "90" diagnostics first, (See section 4.4) before proceeding. The write "90" must be set before entering a block write command so that the verification process can determine if the first block write command sent is valid or not.*

2. The weight controller receives the block number command from the server, verifies that the block number is correct, processes the weight data and prepares a response byte (an error code response number) to the server 's command.

 NOTES: *Changes to Block Writes/Charts should be made in program mode.*

To prevent errors and erroneous data from being sent to the HI 2151 Series Weight Controller, in run mode, follow the procedures below:

1. *Set the Write Block Number to "0".*
2. *Write the new parameter to the output buffer.*
3. *Change the Block Number from "0" to the new number.*

4.4 RESPONSE/ERROR CODE SETUP

1. The server 's PROFIBUS diagnostics capability determines if the error code information is automatically displayed on the server screen. The error code number indicates if the parameter number write command is valid. (See Chapter 8, paragraphs 8.2.3 and 8.2.4)

If the PROFIBUS diagnostics are built into the server, an error code response number is automatically displayed.

 NOTES: *The first 6 bytes of the diagnostic information is reserved as defined in the Profibus Standard. Bytes 7-12 are used by the HI 2151 Series PROFIBUS interface option to provide automatic response/error codes.*

If the PROFIBUS diagnostics are not built in to the server - a write number "90" must be performed to get the error code response.

All write commands require a 50 millisecond response delay.

The write "90" command is used for Block Transfers only, for Selectable Transfers a write "0" command is used.

2. Use write "90" procedures to retrieve an error code response number. For the Error Code List, See Chapter 8.

- a. Enter the following information to output to the weight controller:
 - K1: Contains Hex 5400 (Selects Block Write #84: Selects Read Summary Data)
 - K2: Contains Hex 5A00 (Selects Block "90" error code:)
- b. MOVW1: Downloads the information in K1 & K2 into WY17-WY18 (Weight Controller)
- c. Data is read to: WX1-WX2:
 - WX1: Contains Hex 5A00 (Block Read Summary Data #90)
 - WX2: Contains Error Code (Error code number from the Error Code Table, See Below)

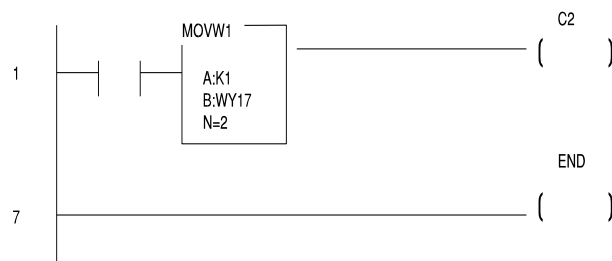

4.5 BLOCK READ COMMAND SETUP

1. Use the Block Write Command 84 (54 hex) to select the Block Read Number(s).
2. On initial start up if no Block number is selected, the PROFIBUS Interface Option will return a Default Block Number, which is Block Read Data number 20 (14 hex): Instrument Identification.

Block Write Command Number 84: Select Block Read Data	
Byte definitions:	
Block Write Number 84 (Hex 54)	
Select Read Type	
Block Read	Value 0
Enter Block Number	

4.6 BLOCK READ EXAMPLE

1. The following example is a setup to read the Full Status and Weight Data from the HI 2151 Series Weight Controller.

Move Word 1 (MOVW1) selects the Block to Read, in this case 20 (14 hex) - Full Status and Weight Data. Block 20 (14 hex) has 15 words, therefore the data is transferred to WX1 through WX15.

- K1: Contains hex 5400 (Block 84: Select Read Summary Data)
- K2: Contains hex 1400 (Block 20: Full Status and Weight Data - The block number to read)

C1: When C1 is ON, Block Read 20 information is read to WX1-WX15

MOVW1: Downloads the information in K1 and K2 into WY17 and WY18 (weight controller)

- Data is read to WX1 - WX15

**HI 2151 Series Weight Controller
Profibus Interface Option**

4.7 SET POINT STATUS/DESCRIPTION BYTES

4.7.1 SET POINT STATUS

Relay 8	Relay 7	Relay 6	Relay 5	Relay 4	Relay 3	Relay 2	Relay 1
Bit 0	Bit 1	Bit 2	Bit 3	Bit 4	Bit 5	Bit 6	Bit 7

 **NOTE:** *Relays 1 and 2 are swapped on bits 6 and 7 for set point status.*

4.7.2 SET POINT DESCRIPTION

- The set point value is the target weight or level. The set points can be set to track peak, gross, net, rate-of-change (ROC) or total. Here is a description of the set point mode selection:

Peak	0
Gross	1
Net	2
ROC	3
Total	4

Example:

The proper set point description bytes for the desired Relay types are as follows:

Relays	LSB/MSB
Relay 1 = Gross Relay 2 = Net	0102
Relay 3 = ROC (Rate-of-Change) Relay 4 = Peak	0300
Relay 5 = Total Relay 6 = Gross	0401
Relay 7 = Gross Relay 8 = Gross	0101

4.8 BLOCK READ DATA NUMBERS

Block Read Data Number 20: Full Status and Weight Data					
Byte Definitions	Byte Pos.	# Words	Start Word	# Bytes	Start Byte
Block Read Number 20 (Hex 14)	LSB	1	0	1	0
Indicator Status 1	MSB			1	1
Rate of Change currently displayed	bit 0				
Set point Relay 2 Active	bit 1				
Set point Relay 1 Active	bit 2				
Peak Force (weight) currently displayed	bit 3				
Totalized weight currently displayed	bit 4				
Reserved for future use	bit 5				
Reserved for future use	bit 6				
Reserved for future use	bit 7				
Indicator Status 2	LSB	1	1	1	2
Weight currently displayed in pounds units	bit 0				
Zero Track feature enabled	bit 1				
Reserved for future use	bit 2				
Current Gross weight = 0	bit 3				
Weight in motion, i.e. changing	bit 4				
Gross Weight currently displayed	bit 5				
Net Weight currently displayed	bit 6				
Weight currently displayed in kilogram units	bit 7				
Dipswitch Settings (Exterior)	MSB			1	3
Re-calibrate toggle	bit 0				
Option menu keypad lockout	bit 1				
Set point menu keypad lockout	bit 2				
Lb/Kg, Net/Gr, Tare, Zero keypad lockout	bit 3				
Zero tracking enable	bit 4				
Reserved for future use	bit 5				
RS 232 command lockout	bit 6				
Multi-drop enable (RS 422 only)	bit 7				
Dipswitch Settings (Interior)	LSB	1	2	1	4
Reserved for future use	bit 0				
Enable Gross Weight output on RS232 port once per second	bit 1				
Calibration lockout for NTEP (Legal for Trade) mode	bit 2				
Ignore incoming serial checksums (RS232 port)	bit 3				
Peak force is a result of averaged gross weight	bit 4				
NTEP (Legal for Trade) mode enable	bit 5				
Eliminate ">" on print out (RS232 port)	bit 6				
Reserved for blind unit toggle	bit 7				
Remote Functions Status	MSB			1	5
Force display to Rate-of-Change	bit 0				
Add current net weight to total	bit 1				
Hold value on display	bit 2				
Hold option card updates	bit 3				
Force display to Net weight mode	bit 4				
Toggle Lbs/Kg	bit 5				

HI 2151 Series Weight Controller
Profibus Interface Option

Acquire Tare Print request (RS232 port)	bit 6 bit 7				
Fixed Point Weight Data					
Rate-of-Change Value		2	3	4	6
Peak Force or Weight		2	5	4	10
Total Weight in Accumulator		2	7	4	14
Gross Weight		2	9	4	18
Net Weight		2	11	4	22
Tare Value		2	13	4	26
Total Words/Bytes		15		30	

Block Read Data Number 21: Floating Point Weight Data (For IEEE Information See Appendix A)					
Byte Definitions	Byte Pos.	# Words	Start Word	# Bytes	Start Byte
Block Read Number 21 (Hex 15)	LSB	1	0	1	0
Reserved for future use	MSB				
Displayed Parameter in floating point, one of the following parameters*				1	1
Rate-of-Change Value		2	1	4	2
Peak Force or Weight					
Total Weight in Accumulator					
Gross Weight					
Net Weight					
Reserved for future use	LSB	1	3	1	6
Currently displayed value type	MSB			1	7
0 = Gross					
1 = Net					
2 = Rate-of-Change					
3 = Peak Hold					
4 = Total Weight					
* Only the currently displayed value is output as floating point, configured via mode button on the front panel.					
Total Words/Bytes		4		8	

 **NOTE:** For Set Point Status and Description Byte information please see Paragraph 4.7.

Section 4: Block Reads

Block Read Data Number 22: Set Point Relay Status 1-2					
Byte Definitions	Byte Pos.	# Words	Start Word	# Bytes	Start Byte
Block Read Number 22 (Hex 16)	LSB	1	0	1	0
Set point Status on/off (See Paragraph 4.7.1)	MSB			1	1
Set point Description #1	LSB	1	1	1	2
Set point Description #2	MSB			1	3
Set point Value #1		2	2	4	4
Preact Value #1		2	4	4	8
Dead band Value #1		2	6	4	12
Set point Value #2		2	8	4	16
Preact Value #2		2	10	4	20
Dead band Value #2		2	12	4	24
Total Words/Bytes		14		28	

Block Read Data Number 23: Set Point Relay Status 3-4					
Byte Definitions	Byte Pos.	# Words	Start Word	# Bytes	Start Byte
Block Read Number 23 (Hex 17)	LSB	1	0	1	0
Set point Status on/off (See Paragraph 4.7.1)	MSB			1	1
Set point Description #3	LSB	1	1	1	2
Set point Description #4	MSB			1	3
Set point Value #3		2	2	4	4
Preact Value #3		2	4	4	8
Dead band Value #3		2	6	4	12
Set point Value #4		2	8	4	16
Preact Value #4		2	10	4	20
Dead band Value #4		2	12	4	24
Total Words/Bytes		14		28	

HI 2151 Series Weight Controller
Profibus Interface Option

Block Read Data Number 24: Set Point Relay Status 5-6					
Byte Definitions	Byte Pos.	# Words	Start Word	# Bytes	Start Byte
Block Read Number 24 (Hex 18)	LSB	1	0	1	0
Set point Status on/off (See Paragraph 4.7.1)	MSB			1	1
Set point Description #5	LSB	1	1	1	2
Set point Description #6	MSB			1	3
Set point Value #5		2	2	4	4
Preact Value #5		2	4	4	8
Dead band Value #5		2	6	4	12
Set point Value #6		2	8	4	16
Preact Value #6		2	10	4	20
Dead band Value #6		2	12	4	24
Total Words/Bytes		14		28	

Block Read Data Number 23: Set Point Relay Status 7-8					
Byte Definitions	Byte Pos.	# Words	Start Word	# Bytes	Start Byte
Block Read Number 25 (Hex 19)	LSB	1	0	1	0
Set point Status on/off (See Paragraph 4.7.1)	MSB			1	1
Set point Description #7	LSB	1	1	1	2
Set point Description #8	MSB			1	3
Set point Value #7		2	2	4	4
Preact Value #7		2	4	4	8
Dead band Value #7		2	6	4	12
Set point Value #8		2	8	4	16
Preact Value #8		2	10	4	20
Dead band Value #8		2	12	4	24
Total Words/Bytes		14		28	

Section 4: Block Reads

Block Read Data Number 26: Read Tare Value					
Byte Definitions	Byte Pos.	# Words	Start Word	# Bytes	Start Byte
Block Read Number 26 (Hex 1A) Reserved for future use	LSB	1	0	1	0
	MSB			1	1
Read Tare Value		2	1	4	2
Total Words/Bytes		3		6	

Block Read Data Number 28: Calibration Parameters					
Byte Definitions	Byte Pos.	# Words	Start Word	# Bytes	Start Byte
Block Read Number 28 (Hex 1C) Reserved for future use	LSB	1	0	1	0
	MSB			1	1
Calibration Parameters:					
Decimal Point Position	LSB	1	1	1	2
Units of Measure (0 = Pounds 1 = Kilograms)	MSB			1	3
C2 [®] , Second Generation Calibration Load Cell Count (One # found on power-up)	LSB	1	2	1	4
Totalizer Decimal Position	MSB			1	5
Display Graduation Size ("count by")		1	3	2	6
Motion Tolerance*		1	4	2	8
Zero Tolerance		1	5	2	10
Number of readings averaged*		1	6	2	12
Span weight value or C2 [®] Reference pont		2	7	4	14
Scale Capacity		2	9	4	18
Mid-point Linearity Calibration Value		2	11	4	22
Auto Zero Tolerance		1	13	2	26
* NOTE: If this read is performed while scale is in the calibration mode, the motion tolerance is "3" and number of readings averaged is "200".					
Total Words/Bytes		14		28	

 NOTE: *The data in Block Read #29 is not valid for the HI 2151/30WC.*

Section 4: Block Reads

NOTE: *The data in Block Read #32 is not valid for the HI 2151/30WC.*

Block Read Data Number 32: Configuration of Standard RS232 Port					
Byte Definitions	Byte Pos.	# Words	Start Word	# Bytes	Start Byte
Block Read Number 32 (Hex 20)	LSB	1	0	1	0
Reserved for future use	MSB			1	1
Reserved for future use	LSB	1	1	1	2
Format of Printout	MSB			1	3
Print Initiation (0 = Continuous, 1 = Altered print)	bit 0				
Set point, Dead band and Preact	bit 1				
Rate-of-Change	bit 2				
Tare Weight	bit 3				
Net Weight	bit 4				
Gross Weight	bit 5				
Print Initiation (0 = Continuous, 1 = Altered print)	bit 6				
Reserved for future use (must be set to 0)	bit 7				
Baud Rate (0 = 600, 1 = 1200, 2 = 2400, 3 = 4800, 4 = 9600, 5 = 19200)	LSB	1	2	1	4
Port Configuration (must be set to 1 for printer output only)	MSB			1	5
Stop Bits (0 = one stop bit, 1 = two stop bits)	LSB	1	3	1	6
Parity (0 = none, 1 = even, 2 = odd)	MSB			1	7
Handshake Control (0 = hardware, 1 = software)	LSB	1	4	1	8
Word Length (0 = seven bits, 1 = eight bits)	MSB			1	9
Device Address (a value from 0-99)	LSB	1	5	1	10
Echo (0 = off, 1 = on)	MSB			1	11
Total Words/Bytes		6		12	

Block Read Data Number 34: Operator Selectable Read Summary Data					
Byte Definitions	Byte Pos.	# Words	Start Word	# Bytes	Start Byte
Block Read Number 34 (Hex 22)				1	0
User Defined (Refer to Write Block #84)					

**HI 2151 Series Weight Controller
Profibus Interface Option**

Block Read Data Number 35: Instrument Identification					
Byte Definitions	Byte Pos.	# Words	Start Word	# Bytes	Start Byte
Block Read Number 35 (Hex 23)	LSB	1	0	1	0
Firmware revisions level (one character text, i.e. "A")	MSB	2	1	4	2
Firmware version (ASCII text number)		2	3	4	6
Zero Calibration analog to digital converter raw counts		2	5	4	10
Span Calibration analog to digital converter raw counts		2			
Total Words/Bytes		7		14	

Block Read Data Number 36: Floating Point Data					
Byte Definitions	Byte Pos.	# Words	Start Word	# Bytes	Start Byte
Block Read Number 36 (Hex 24)	LSB	1	0	1	0
Reserved for Future Use	MSB	1		1	1
Gross Weight (Floating Point)		2	1	4	2
ROC Data (Floating Point)		2	3	4	6
Total Words/Bytes		5		10	

Block Read Data Number 37: Integrated Technician Status					
Byte Definitions	Byte Pos.	# Words	Start Word	# Bytes	Start Byte
Block Read Number 37 (Hex 25)	LSB	1	0	1	0
Excitation Monitor ON/OFF 1 = ON 0 = OFF	MSB	1		1	1
Excitation Monitor Error (1 - Error, 0 = OK)	LSB	1	1	1	2
Reserved for Future Use	MSB	1		1	3
Total Words/Bytes		2		4	

Section 5 Block Writes

5.1 SCOPE

Chapter 5 covers block write commands for the PROFIBUS Interface Option. Programmers and other users be familiar with this chapter before operating the PROFIBUS Interface Option.

5.2 OVERVIEW OF TRANSFER COMMANDS

1. PROFIBUS Interface Card maximum buffer size 112 byte buffer
2. Siemens PLC
 - a. TI 505 Series PLC
 - Requires the Field Interface Module (FIM) to communicate over PROFIBUS.
 - Can continually exchange up to 32 words or 64 bytes for both server input and output with each client device.
 - b. S5 Series PLC
 - Requires IM 308C Module to communicate over PROFIBUS.
 - Can continually exchange up to 244 bytes for server input and output with each client device.
 - c. S7 Series PLC
 - PROFIBUS ready, does not require additional modules.
 - Can Continually exchange up to 244 bytes for server input and output with each client device.
3. Allen-Bradley PLC5 Series
 - a. Requires PROFIBUS DP module to communicate over PROFIBUS.
 - b. Can continually exchange up to 244 bytes for both server Input and Output with each client device.

5.3 OVERVIEW OF BLOCK TRANSFER COMMANDS

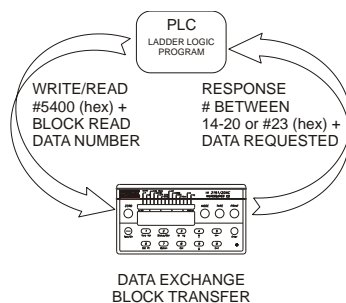

1. It is important to keep in mind that the amount of bytes that can be transferred is determined by the server not the PROFIBUS interface option.
2. When using the HI 2151 Series Weight Controller PROFIBUS interface, the user can select the Block Read Data and Block Write Commands as required. However, the amount of bytes that can be transferred is dependent on the data transfer capability of the server being used.
3. The ladder logic program provides the server with the ability to read and write weight data by referencing the PROFIBUS address, the byte numbers and number of bytes.

HI 2151 Series Weight Controller Profibus Interface Option

 NOTE: *The weight controller will not accept write commands until calibration is sealed. Press "Enter" at ENDCAL to seal the calibration. (See HI 2151 Series Weight Controller Operation and Installation Manual, for calibration instructions)*

5.4 DETAILED COMMAND SET FOR BLOCK TRANSFER (WRITES)

 NOTE: *We recommend that front panel functions be controlled through the PROFIBUS network and that the front panel control be disabled or locked out. (See the HI 2151 Series Weight Controller Operation and Installation Manual (#0596-0178), for lockout instructions)*

1. All write commands are initiated by the server using a ladder logic program to send a block number to the HI 2151/20WC.

 NOTE: *If your server device **does not** have built in PROFIBUS diagnostic capability set up the Response/Error "90" diagnostics first, (See section 4.4) before proceeding. The write "90" must be set before entering a block write command so that the verification process can determine if the first block write command sent is valid or not.*

2. The weight controller receives a block number command, verifies that the block number is correct, processes the weight data and prepares a response byte (an error code response number) to the server's command.

 NOTE: *Changes to Block Writes/Charts should be made in program mode.*

5.5 BLOCK WRITE EXAMPLE

 NOTE: *When making changes to block writes in run mode, follow the procedures below:*

1. *Set the Block Number to "0".*
2. *Write the new parameter to the output buffer.*
3. *Change the Block Number from "0" to the new number.*

The following example is a setup to download set point #1 and #2 values, preacts and dead bands using Block Write Command 72 (48 hex): Set point Relay Status 1 & 2.

 NOTE: *Any set point, preact and dead band values can be entered into K memory.*

When C1 is activated the Move Word 1 (MOVW1) downloads the information to the weight controller using WY17 through WY31.

- K1: Contains hex 48FF (Selects Block 72 and enables set point relays 1 and 2)
- K2: Contains hex 0102 (Sets relay 1 to Gross and relay 2 to Net)
- K3: Contains Double 1000 (Sets set point 1 to 1,000)
- K5: Contains Double - 5 (Sets Preact 1 to negative -5)
- K7: Contains Double - 10 (Sets Dead band 1 to negative -10)
- K9: Contains Double - 100 (Sets set point 2 to negative -100)
- K11: Contains Double 5 (Sets Preact 2 to 5)
- K13: Contains Double 10 (Sets Dead band 2 to 10)

C1: Starts the program

MOVW1: Downloads the information in K1-K14 into WY17-WY31 (weight controller)

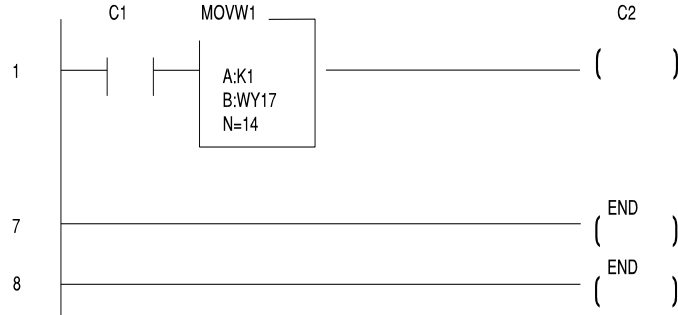

5.6 BLOCK WRITE COMMAND NUMBERS

Block Write Command Number 70: Activate Scale Functions					
Byte Definitions	Byte Pos.	# Words	Start Word	# Bytes	Start Byte
Block Write Number 70 (Hex 46) Activate by setting remote functions bit to 1 then reset to 0	LSB MSB	1	0	1	0
TARE = Current Gross Weight	bit 0			1	1
Initiates print on standard RS232	bit 1				
Add current net weight to Total	bit 2				
Clear Peak Hold	bit 3				
Clear Totalizer Accumulator	bit 4				
Zero the Instrument	bit 5				
Enable Zero Tracking (blind unit only)	bit 6				
Reserved for future use	bit 7				
Total Words/Bytes		1		1	

Block Write Command Number 71: Force Relay Status					
Byte Definitions	Byte Pos.	# Words	Start Word	# Bytes	Start Byte
Block Write Number 71 (Hex 47) Activate by setting remote functions bit to 1 then reset to 0	LSB MSB	1	0	1	0
Relay 8	bit 0			1	1
Relay 7	bit 1				
Relay 6	bit 2				
Relay 5	bit 3				
Relay 4	bit 4				
Relay 3	bit 5				
Relay 2	bit 6				
Relay 1	bit 7				
Total Words/Bytes		1		2	

HI 2151 Series Weight Controller
Profibus Interface Option

Block Write Command Number 72: Set point Relay Status 1-2					
Byte Definitions	Byte Pos.	# Words	Start Word	# Bytes	Start Byte
Block Write Number 72 (Hex 48)	LSB	1	0	1	0
Set point Enable on/off (See Chapter 4, paragraph 4.7.1)	MSB			1	1
Set point #1	bit 7				
Set point #2	bit 6				
Set point Description #1	LSB	1	1	1	2
Set point Description #2	MSB			1	3
Set point Value #1		2	2	4	4
Preact Value #1		2	4	4	8
Dead band Value #1		2	6	4	12
Set point Value #2		2	8	4	16
Preact Value #2		2	10	4	20
Dead band Value #2		2	12	4	24
Total Words/Bytes		14		28	

 **NOTE:** For Set point Status and Description Byte information please See Chapter 4, Paragraph 4.6.

Block Write Command Number 73: Set point Relay Status 3-4					
Byte Definitions	Byte Pos.	# Words	Start Word	# Bytes	Start Byte
Block Write Number 73 (Hex 49)	LSB	1	0	1	0
Set point Enable on/off (See Chapter 4, paragraph 4.7.1)	MSB			1	1
Set point #3	bit 5				
Set point #4	bit 4				
Set point Description #3	LSB	1	1	1	2
Set point Description #4	MSB			1	3
Set point Value #3		2	2	4	4
Preact Value #3		2	4	4	8
Dead band Value #3		2	6	4	12
Set point Value #4		2	8	4	16
Preact Value #4		2	10	4	20
Dead band Value #4		2	12	4	24
Total Words/Bytes		14		28	

Section 5: Block Writes

Block Write Command Number 74: Set point Relay Status 5-6					
Byte Definitions	Byte Pos.	# Words	Start Word	# Bytes	Start Byte
Block Write Number 74 (Hex 4A)	LSB	1	0	1	0
Set point Enable on/off (See Chapter 4, paragraph 4.7.1)	MSB			1	1
Set point #5	bit 3				
Set point #6	bit 2				
Set point Description #5	LSB	1	1	1	2
Set point Description #6	MSB			1	3
Set point Value #5		2	2	4	4
Preact Value #5		2	4	4	8
Dead band Value #5		2	6	4	12
Set point Value #6		2	8	4	16
Preact Value #6		2	10	4	20
Dead band Value #6		2	12	4	24
Total Words/Bytes		14		28	

Block Write Command Number 75: Set point Relay Status 7-8					
Byte Definitions	Byte Pos.	# Words	Start Word	# Bytes	Start Byte
Block Write Number 75 (Hex 4B)	LSB	1	0	1	0
Set point Enable on/off (See Chapter 4, paragraph 4.7.1)	MSB			1	1
Set point #7	bit 1				
Set point #8	bit 0				
Set point Description #7	LSB	1	1	1	2
Set point Description #8	MSB			1	3
Set point Value #7		2	2	4	4
Preact Value #7		2	4	4	8
Dead band Value #7		2	6	4	12
Set point Value #8		2	8	4	16
Preact Value #8		2	10	4	20
Dead band Value #8		2	12	4	24
Total Words/Bytes		14		28	

**HI 2151 Series Weight Controller
Profibus Interface Option**

Block Write Command Number 76: Send Tare Value					
Byte Definitions	Byte Pos.	# Words	Start Word	# Bytes	Start Byte
Block Write Number 76 (Hex 4C) Reserved for future use	LSB	1	0	1	0
	MSB			1	1
Send Tare Value		2	1	4	2
Total Words/Bytes		3		6	

Block Write Command Number 77: Scale Calibration Action					
Byte Definitions	Byte Pos.	# Words	Start Word	# Bytes	Start Byte
Block Write Number 77 (Hex 4D)	LSB	1	0	1	0
Activate by setting and then clearing	MSB			1	1
Current weight is an empty scale	bit 0				
Current weight is span weight	bit 1				
Store critical data in the Secure Memory Module	bit 2				
Restore critical data from the Secure Memory Module	bit 3				
Current weight is Midpoint Linearity value	bit 4				
Reserved for future use	bit 5				
Current weight is the C2 [®] reference point	bit 6				
Reserved for future use	bit 7				
Total Words/Bytes		1		2	

Block Write Command Number 78: Scale Calibration Action					
Byte Definitions	Byte Pos.	# Words	Start Word	# Bytes	Start Byte
Block Write Number 78 (Hex 4E) Reserved for future use	LSB	1	0	1	0
	MSB			1	1
Calibration Parameters:					
Decimal Point Position	LSB	1	1	1	2
Units of Measure (0 = Pounds 1 = Kilograms)	MSB			1	3
C2 [®] , Second Generation Calibration Load Cell Count . (One # found on power-up)	LSB	1	2	1	4
Totalizer Decimal Position	MSB			1	5
Display Graduation Size ("count by")		1	3	2	6
Motion Tolerance					

**HI 2151 Series Weight Controller
Profibus Interface Option**

Weight Parameter (Value) 0 = Gross 1 = Net 2 = Rate-of-Change 3 = Peak Hold 4 = Total Weight	MSB			1	1
Weight Value Represented by a Zero Scale Analog Output		2	1	4	2
Weight Value Represented by a Full Scale Analog Output		2	3	4	6
Total Words/Bytes		5		10	

☞ NOTE: *This Block Write (#82) is not valid for HI 2151/30WC*

Block Write Command Number 82: Configuration of Standard RS232 Port					
Byte Definitions	Byte Pos.	# Words	Start Word	# Bytes	Start Byte
Block Read Number 82 (Hex 52)	LSB	1	0	1	0
Reserved for future use	MSB			1	1
Reserved for future use	LSB	1	1	1	2
Format of Printout	MSB			1	3
Print Initiation (0 = Continuous, 1 = Altered print)	bit 0				
Set point, Dead band and Preact	bit 1				
Rate-of-Change	bit 2				
Tare Weight	bit 3				
Net Weight	bit 4				
Gross Weight	bit 5				
Print Initiation (0 = Continuous, 1 = Altered print)	bit 6				
Reserved for future use (must be set to 0)	bit 7				
Baud Rate (0 = 600, 1 = 1200, 2 = 2400, 3 = 4800, 4 = 9600, 5 = 19200)	LSB	1	2	1	4
Port Configuration (must be set to 1 for printer output only)	MSB			1	5
Stop Bits (0 = one stop bit, 1 = two stop bits)	LSB	1	3	1	6
Parity (0 = none, 1 = even, 2 = odd)	MSB			1	7
Handshake Control (0 = hardware, 1 = software)	LSB	1	4	1	8
Word Length (0 = seven bits, 1 = eight bits)	MSB			1	9
Device Address (a value from 0-99)	LSB	1	5	1	10
Echo (0 = off, 1 = on)	MSB			1	11
Total Words/Bytes		6		12	

Section 5: Block Writes

Block Write Command Number 85: Integrated Technician					
Byte Definitions	Byte Pos.	# Words	Start Word	# Bytes	Start Byte
Block Write Number 85 (Hex 55)					
WAVERSAVER (1-5)					
Excitation Monitor 0 = OFF 1 = ON	MSB	1	0	2	0
Enter Block number (only one) or Selectable parameter	LSB	1	1	1	1
Reserved for future use	MSM				

Block Write Command Number 83: Personalized Selection of Write Commands					
Byte Definitions	Byte Pos.	# Words	Start Word	# Bytes	Start Byte
Block Write Number 83 (Hex 53)					
Reserved for future use	LSB	1	0	1	0
Reserved for future use	MSB			1	1
Enter Parameter Number	LSB	1	1	1	1
Reserved for future use	MSB			1	
Enter Parameter Value	LSB	1 or 2		1.2 or 4	
Reserved for future use (if selection is one byte long)	MSB			0 or 1	
Repeat for all Write commands desired*				1	
FF (End)					
*Note: Be sure not to go over the byte limit of the server					

Block Write Command Number 84: Select Read Summary Data					
Byte Definitions	Byte Pos.	# Words	Start Word	# Bytes	Start Byte
Block Write Number 84 (Hex 54)					
Select Read Type	Value				
Block Read (defaults to block #35 Instrument Identification)	0			1	1
Selectable Read	1				
Enter Block number (only one) or Selectable parameter number)* (Repeat for all selected parameter number)					
FF (End)					
*Note: Be sure not to go over the byte limit of the server					

Section 6 SELECTABLE READS

6.1 SCOPE

Chapter 6 covers Selectable Read Commands for the PROFIBUS Interface Option.

6.2 OVERVIEW OF TRANSFER COMMANDS

1. PROFIBUS Interface Card maximum buffer size: 112 byte buffer
2. Siemens PLC
 - a. TI 505 Series PLCs
 - Requires the Field Interface Module (FIM) to communicate over PROFIBUS.
 - Can continually exchange up to 32 words or 64 bytes for both PLC input and output with each client device.
 - b. S5 Series PLCs
 - Requires IM 308C Module to communicate over PROFIBUS.
 - Can continually exchange up to 244 bytes for PLC input and output with each client device.
 - c. S7 Series PLC
 - PROFIBUS ready, does not require additional modules.
 - Can Continually exchange up to 244 bytes for PLC input and output with each client device.
3. Allen-Bradley PLC5 Series
 - a. Requires PROFIBUS DP module to communicate over PROFIBUS.
 - b. Can continually exchange up to 244 bytes for both PLC Input and Output with each client device.

6.3 OVERVIEW OF SELECTABLE TRANSFER COMMANDS

1. It is important to keep in mind that the amount of bytes that can be transferred is determined by the server PLC not the PROFIBUS interface option.
2. When using the HI 2151 Series Weight Controller PROFIBUS interface, the user can select the Read Data Summaries and Write Commands they require. However, the amount of bytes that can be transferred is dependent on the data transfer capability of the server being used.
3. By sending the proper commands to the HI 2151 Series Weight Controller, the server can specify which weighing parameters and/or status bits should be provided.
4. The ladder logic program provides the server with the ability to read and write weight data by referencing the PROFIBUS address, the parameter numbers and number of bytes.



NOTE:

The decimal point is not included in values transferred. The decimal position is a separate parameter.

6.4 DETAILED DATA SET FOR SELECTABLE READ(S)

1. The Selectable Read data to be input to the server is always initiated by a Block Write Command designating the parameter number that the HI 2151 Series Weight Controller will send to the server.

 **NOTE:** *If your server Device **does not** have built in PROFIBUS diagnostic capability set up the Response/Error “0” diagnostics first, (See section 4.4) before proceeding. The write “0” must be set before entering a block write command so that the verification process can determine if the first block write command sent is valid or not.*

2. The weight controller receives the parameter number command from the server, verifies that the parameter number is correct, processes the weight data and prepares a response byte (an error code response number) to the server’s command.

 **NOTES:** *Changes to Block Writes/Charts should be made in program mode.*

To prevent errors and erroneous data from being sent to the HI 2151 Series Weight Controller in run mode, follow the procedures below:

1. *Set the Block Number to “0”.*
2. *Write the new parameter to the output buffer.*
3. *Change the Block Number from “0” to the new number.*

6.5 SELECTABLE READ COMMAND SETUP PROCEDURES

1. Selectable Read Data use Block Write Number 84 (5401 hex). Block Read number 34 (2200 hex) is returned as an input to the PLC.
2. Block write number 84 allows the user to select the read data summaries desired, and they are returned in Operator Selectable Read block 34.

Block Write Command Number 84: Select Read Data
Byte definitions:
Block Write Number 84 (54 Hex)
Select Read Type
Selectable Read Value 1
Enter parameter number (repeat parameter numbers but do not exceed word/byte limit of the PLC)
FF (end)

Operator Selectable Read Data Number 34
Byte Definitions:
Operator Selectable Read Data Number 34 (22 Hex)
Unused Byte 00
Reads operator selectable commands setup in Block Write Number 84 (Hex)

HI 2151 Series Weight Controller Profibus Interface Option

Full word variables must begin on word boundaries, when transferring operator selectable commands or data. See example below.

Example Output from the PLC, in this example indicator status 2 is desired. Indicator status 1, is used so that Tare Value starts at a word boundary:

<u>Byte</u>	<u>Hex#</u>	<u>Description</u>
Byte 0	54	Block Write Number
Byte 1	01	Selectable Read
Byte 2	02	Indicator Status 2
Byte 3	01	Indicator Status 1 (used to maintain word boundaries)
Byte 4	3C	Tare Value
Byte 6	FF	END

Example Input to the PLC, indicates the data returned to the PLC from the output above.

<u>Byte</u>	<u>Hex#</u>	<u>Description</u>
Byte 0	22	Block Read Number
Byte 1	00	Unused
Byte 2	21	Gross Weight (bit 5) in Pounds (bit 0 is displayed)
Byte 3	00	Used as place holder (indicator status 1)
Byte 4-7	00	Tare Value = 100 (hex)
	01	
	00	

 **NOTE:** For outputs from the PLC "00" cannot be used to align word boundaries, because it returns two bytes.

6.6 SELECTABLE READ COMMAND EXAMPLE

The following example is to setup read set point #1 and #2 values (without preacts and dead bands).

1. When C1 is activated Move Word 1 (MOVW1) reads the information from the weight controller using WX1 through WX5.
 - a. K1: Contains hex 5401 (Selects Block Write 84: Select Read Summary Data)
 - b. K2: Contains hex 181B (Selects parameter 24 Set Point #1 and parameter 27 = Set Point #2)
 - c. K3: Contains hex FFFF (Ends the Selection)
2. C1: Starts the Program
3. MOVW1: Downloads the information in K1-K3 into WY17-WY19 (Weight Controller)
4. Data is read to WX1- WX5:
 - a. WX1: Contains hex(Operator Selectable Read Summary Data 34
 - b. WX2: Contains Double + 790 (Set point 1 has a value of 790) Example value only
 - c. WX4: Contains Double + 800 (Set point 2 has a value of 800) Example value only.

6.7 SELECTABLE READ DATA

6.7.1 FULL STATUS AND WEIGHT DATA

Full Status and Weight Data		# Words	# Bytes	Parameter #	Hex Number
Indicator Status 1		0.5	1	1	1
Rate of Change currently displayed	bit 0				
Set point Relay 2 Active	bit 1				
Set point Relay 1 Active	bit 2				
Peak Force (weight) currently displayed	bit 3				
Totalized weight currently displayed	bit 4				
Reserved for future use	bit 5				
Reserved for future use	bit 6				
Reserved for future use	bit 7				
Indicator Status 2		0.5	1	2	2
Weight currently displayed in pounds units	bit 0				
Zero Track feature enabled	bit 1				
Reserved for future use	bit 2				
Current Gross weight = 0	bit 3				
Weight in motion, i.e. changing	bit 4				
Gross Weight currently displayed	bit 5				
Net Weight currently displayed	bit 6				
Weight currently displayed in kilogram units	bit 7				
Dipswitch Settings (Exterior)		0.5	1	3	3
Re-calibrate toggle	bit 0				
Option menu keypad lockout	bit 1				
Set point menu keypad lockout	bit 2				
Lb/Kg, Net/Gr, Tare, Zero keypad lockout	bit 3				
Zero tracking enable	bit 4				
Reserved for future use	bit 5				
RS 232 command lockout	bit 6				
Multi-drop enable (RS 422 only)	bit 7				
Dipswitch Settings (Interior)		0.5	1	4	4
Reserved for future use	bit 0				
Enable Gross Weight output on RS232 port once per second	bit 1				
Calibration lockout for NTEP (Legal for Trade) mode	bit 2				
Ignore incoming serial checksums (RS232 port)	bit 3				
Peak force is a result of averaged gross weight	bit 4				
NTEP (Legal for Trade) mode enable	bit 5				
Eliminate ">" on print out (RS232 port)	bit 6				
Reserved for blind unit toggle	bit 7				
Remote Functions Status		0.5	1	5	5
Force display to Rate-of-Change					
Add current net weight to total					
Hold value on display	bit 0				
Hold option card updates	bit 1				
Force display to Net weight mode	bit 2				
Toggle Lbs/Kg	bit 3				

HI 2151 Series Weight Controller Profibus Interface Option

Acquire Tare	bit 4			
Print request (RS232 port)	bit 5			
	bit 6			
Fixed Point Weight Data	bit 7			
Rate-of-Change Value				
Peak Force or Weight				
Total Weight in Accumulator	2	4	6	6
Gross Weight	2	4	7	7
Net Weight	2	4	8	8
Tare Value	2	4	9	9
	2	4	10	A
	2	4	11	B

6.7.2 FLOATING POINT WEIGHT DATA

Floating Point Weight Data	# Words	# Bytes	Parameter #	Hex Number
Displayed Parameter in floating point, one of the following parameters*: Rate-of-Change Value Peak Force or Weight Total Weight in Accumulator Gross Weight Net Weight	2	4	15	F
Currently displayed value type 0 = Gross 1 = Net 2 = Rate-of-Change 3 = Peak Hold 4 = Total Weight	0.5	1	16	10

*Note: Only the currently displayed value is output as floating point, configured via write command

6.7.3 SET POINT RELAY STATUS 1-8

Set point Relay Status 1-8	# Words	# Bytes	Parameter #	Hex Number
Set point Status - on/off for all 8 relays (See Chapter 4, para.4.7.1)	0.5	1	20	14
Set point Description (See Chapter 4, para. 4.7.2)				
Set point #1	1	1	22	16
Set point #2		1	23	17
Set point #3	1	1	32	20
Set point #4		1	33	21
Set point #5	1	1	42	2A
Set point #6		1	43	2B
Set point #7	1	1	52	34
Set point #8		1	53	35
Set point #1				
Set point Value #1	2	4	24	18
Preact Value #1	2	4	25	19
Dead band Value #1	2	4	26	1A

Section 6: Selectable Reads

Set point #2				
Set point Value #2	2	4	27	1B
Preact Value #2	2	4	28	1C
Dead band Value #2	2	4	29	1D
Set point #3				
Set point Value #3	2	4	34	22
Preact Value #3	2	4	35	23
Dead band Value #3	2	4	36	24
Set point #4				
Set point Value #4	2	4	37	25
Preact Value #4	2	4	38	26
Dead band Value #4	2	4	39	27
Set point #5				
Set point Value #5	2	4	44	2C
Preact Value #5	2	4	45	2D
Dead band Value #5	2	4	46	2E
Set point #6				
Set point Value #6	2	4	47	2F
Preact Value #6	2	4	48	30
Dead band Value #6	2	4	49	31
Set point #7				
Set point Value #7	2	4	54	36
Preact Value #7	2	4	55	37
Dead band Value #7	2	4	56	38
Set point #8				
Set point Value #8	2	4	57	39
Preact Value #8	2	4	58	3A
Dead band Value #8	2	4	59	3B

6.7.4 READ TARE VALUE

Read Tare Value	# Words	# Bytes	Parameter #	Hex Number
Read Tare Value	2	4	60	3C

6.7.5 CALIBRATION PARAMETERS

Calibration Parameters	# Words	# Bytes	Parameter #	Hex Number
Decimal Point Position	0.5	1	66	42
Units of Measure (0 = Pounds 1 = Kg)	0.5	1	67	43
C2 [®] , Second Generation Calibration Load Cell Count (One # found on power-up)	0.5	1	68	44
Totalizer Decimal Position	0.5	1	69	45
Display Graduation Size ("count by")	1	2	70	46
Motion Tolerance	1	2	71	47
Zero Tolerance	1	2	72	48
Number of readings averaged	1	2	73	49
Span weight value or C2 [®] Reference point	2	4	74	4A
Scale Capacity	2	4	75	4B
Mid-point Linearity Calibration Value	2	4	76	4C
Auto Zero Tolerance	1	2	77	4D

**HI 2151 Series Weight Controller
Profibus Interface Option**

6.7.6 STICKER VALUE (NOT VALID FOR THE HI 2151/30WC)

Sticker Value	# Words	# Bytes	Parameter #	Hex Number
Sticker Value	2	4	78	4E

6.7.7 CONFIGURATION OF RATE-OF-CHANGE

Configuration of Rate-of-Change	# Words	# Bytes	Parameter #	Hex Number
Displayed Rate-of-Change time (0 = Sec, 1 = Min, 2 = Hrs)	1	2	80	50
Rate-of-Change time base evaluation period in seconds	1	2	81	51

Time base evaluation period:
 0 = 1 sec 6 = 10 sec 11 = 120 sec
 1 = 2 sec 7 = 12 sec 12 = 240 sec
 2 = 3 sec 8 = 15 sec 13 = 450 sec
 3 = 4 sec 9 = 30 sec 14 = 900 sec
 4 = 5 sec 10 = 60 sec 15 = 1800 sec

6.7.8 CONFIGURATION OF ANALOG OUTPUT

Configuration of Analog Output	# Words	# Bytes	Parameter #	Hex Number
Weight Parameter (Value) 0 = Gross 1 = Net 2 = Rate-of-Change 3 = Peak Hold 4 = Total Weight	0.5	1	85	55
Wt. Value shown by a zero scale analog output	2	4	86	56
Wt Value shown by a full scale analog output	2	4	87	57

6.7.9 CONFIGURATION OF STANDARD RS232 PORT

Configuration of Standard RS232 Port	# Words	# Bytes	Parameter #	Hex Number
Format of Printout	0.5	1	90	5A
Print Initiation (0 = Continuous, 1 =Altered print)*	bit 0			
Set point, Dead band and Preact	bit 1			
Rate-of-Change	bit 2			

6.7.10 INSTRUMENT ID

Instrument ID	# Words	# Bytes	Parameter #	Hex Number
Tare Weight	bit 3			
Net Weight	bit 4			
Gross Weight	bit 5			
Print Initiation (0 = Continuous, 1 = Altered print)	bit 6			
Reserved for future use (must be set to 0)	bit 7			
Baud Rate (0 = 600, 1 = 1200, 2 = 2400, 3 = 4800, 4 = 9600, 5 = 19200)	0.5	1	91	5B
Port Configuration (must be set to 1 for printer output only)	0.5	1	92	5C
Stop Bits (0 = one stop bit, 1 = two stop bits)	0.5	1	93	5D
Parity (0 = none, 1 = even, 2 = odd)	0.5	1	94	5E
Handshake Control (0 = hardware, 1 = software)	0.5	1	95	5F
Word Length (0 = seven bits, 1 = eight bits)	0.5	1	96	60
Device Address (a value from 0-99)	0.5	1	97	61
Echo (0 = off, 1 = on)	0.5	1	98	62

6.7.11 INSTRUMENT IDENTIFICATION

Instrument Identification	# Words	# Bytes	Parameter #	Hex Number
Firmware Revision Level (one character text, i.e. A) (Pursuant to Revision Specification ASME Y14.35M-1992)	0.5	1	100	64
Firmware Version (ASCII text number)	2	4	101	65
Zero Calibration analog-to-digital converter raw counts	2	4	102	66
Span Calibration analog to digital converter raw counts	2	4	103	67

6.7.12 RESPONSE/ERROR CODE

Response/Error Code	# Words	# Bytes	Parameter #	Hex Number
Provide the last write command number with its response/error code. (See Chapter 8 for a list of response/error codes)	1	2	0	0

**HI 2151 Series Weight Controller
Profibus Interface Option**

6.7.13 INTEGRATED TECHNICIAN (NOT VALID FOR HI 2151/20WC)

Integrated Technician	# Words	# Bytes	Parameter #	Hex Number
Excitation Test ON/OFF Flag (upperbyte)	1	2	104	68
Excitation Test Pass/Fail Flag (lowerbyte)				
C2 Reference Point	2	4	105	69
WAVERSAVER	1	1	106	6A

SECTION 7 SELECTABLE WRITES

7.1 SCOPE

Chapter 7 covers Selectable Write Commands for the PROFIBUS Interface Option. It is very important that programmers and users be familiar with this chapter before operating the PROFIBUS Interface Option.

7.2 OVERVIEW OF TRANSFER COMMANDS

1. PROFIBUS Interface Card maximum buffer size: 112 byte buffer
2. Siemens PLC
 - a. TI 505 Series PLCs
 - Requires the Field Interface Module (FIM) to communicate over PROFIBUS.
 - Can continually exchange up to 32 words or 64 bytes for both PLC input and output with each client device.
 - b. S5 Series PLCs
 - Requires IM 308C Module to communicate over PROFIBUS.
 - Can continually exchange up to 244 bytes for PLC input and output with each client device.
 - c. S7 Series PLC
 - PROFIBUS ready, does not require additional modules.
 - Can Continually exchange up to 244 bytes for PLC input and output with each client device.
3. Allen-Bradley PLC5 Series
 - a. Requires PROFIBUS DP module to communicate over PROFIBUS.
 - b. Can continually exchange up to 244 bytes for both PLC Input and Output with each client device.

7.3 OVERVIEW OF SELECTABLE TRANSFER COMMANDS

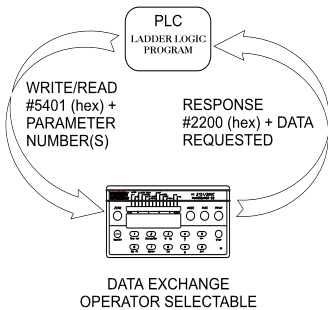

1. It is important to keep in mind that the amount of bytes that can be transferred is determined by the server not the PROFIBUS interface option.
2. When using the HI 2151 Series Weight Controller PROFIBUS interface, the user can select the Read Data Summaries and Write Commands they require. However, the amount of bytes that can be transferred is dependent on the data transfer capability of the server being used.
3. By sending the proper commands to the HI 2151 Series Weight Controller, the server can specify which weighing parameters and/or status bits should be provided.

HI 2151 Series Weight Controller Profibus Interface Option

4. The ladder logic program provides the server with the ability to read and write weight data by referencing the PROFIBUS address, the parameter numbers and number of bytes.

 **NOTE:** *The decimal point is not included in values transferred. The decimal position is a separate parameter.*

7.4 DETAILED COMMAND SET FOR SELECTABLE WRITES

 **NOTE:** *We recommend that front panel functions be controlled through the PROFIBUS network and that the front panel control be disabled or locked out. (See the HI 2151/20 WC Operation and Installation Manual (#0596-0178-B), Section 6, Paragraph 6.3 or HI 2151/30 WC Operation and Installation Manual (#0596-0224-A) Section 4, Paragraph 4.12, for lockout instructions)*

1. All write commands are initiated by the server using a ladder logic program to send the desired parameter number(s) to the HI 2151/20WC weight controller via the PROFIBUS Interface Card. The weight controller receives a parameter number command, verifies that the parameter number is correct, processes the weight data and prepares a response byte (an error code response number) to the PLC's command.

 **NOTE:** *If you server Device **does not** have built in PROFIBUS diagnostic capability set up the Response/Error "0" diagnostics first, (See Section 4.4) before proceeding. The write "0" must be set before entering a selectable write command so that the verification process can determine if the first selectable write command sent is valid or not.*

 **NOTE:** *The write "0" should be the first command written, to ensure that the error codes are displayed on the server screen.*

7.5 SELECTABLE WRITE COMMAND SETUP PROCEDURES

1. Use Block Write Number 83 - Personalized Selection of Write Commands.
2. This block allows the user to select as many write commands up to the byte limit of the PLC.

Block Write Command Number 83: Personalized Selection of Write Commands

Byte definitions:

Block Write Number 83 (Hex 5300)

Unused Byte 00

Enter Parameter Number

Unused Byte

Enter Byte Value

(Repeat for all Write Commands, but do not exceed PLC word/byte limit)

FF (end)



FULL WORD VARIABLES MUST BEGIN ON WORD BOUNDARIES, WHEN TRANSFERRING OPERATOR SELECTABLE COMMANDS OR DATA. SEE EXAMPLE BELOW

Example Output from the server:

<u>Byte</u>	<u>Hex#</u>	<u>Description</u>
Byte 0	53	Block Write Number
Byte 1	00	Unused
Byte 2	42	Decimal Point Position (66)
Byte 3	00	Number ignored
Byte 4	03	3 Decimal Places
Byte 6	3C	Tare Value
<u>Byte</u>	<u>Hex#</u>	<u>Description</u>
Byte 7	00	Number ignored
Byte 8	00	Tare Value = 100 (hex)
Byte 9	00	
Byte 10	01	
Byte 11	00	

7.6 OPERATOR SELECTABLE WRITE EXAMPLE

1. The following example is a setup to download set point #1 and #2 values (without preacts and dead bands).

 NOTE: Any set point value can be entered into K memory.

When C1 is activated the Move Word (MOVW1) downloads the information to the weight controller using WY17 through WY31.

- K1: Contains hex 5300 (Selects Block Write #83)
- K2: Contains hex 1800 (Selects parameter #24 - Set point number 1)
- K3: Contains Double 790 (Sets set point 1 to 790)
- K5: Contains hex 1B00 (Selects parameter #27 - Set point number 2)
- K6: Contains Double 800 (Sets set point 2 to 800)

C1: Starts the program

MOVW1: Downloads the information in K1-K7 into WY17-WY23 (weight controller)

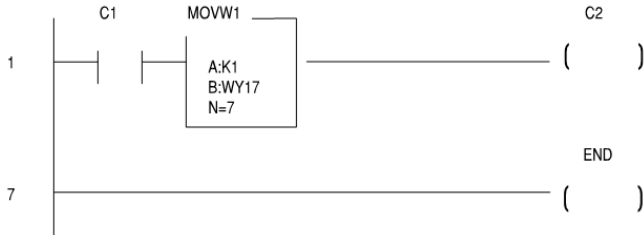

**HI 2151 Series Weight Controller
Profibus Interface Option**

7.7 SELECTABLE WRITE COMMANDS

7.7.1 SET POINT RELAY FUNCTIONS

Set point Relay Functions	# Words	# Bytes	Parameter #	Hex #
Force Relay	0.5	1	19	13
Set point Enable - on/off (See Chapter 4, para. 4.7.1)	0.5	1	20	14*
Set point #1 bit 7			21	15
Set point #2 bit 6			21	15
Set point #3 bit 5			31	1F
Set point #4 bit 4			31	1F
Set point #5 bit 3			41	29
Set point #6 bit 2			41	29
Set point #7 bit 1			51	33
Set point #8 bit 0			51	33
Set point Description (See Chapter 4, para. 4.7.2)	1	1	22	16
Set point #1		1	23	17
Set point #2	1	1	32	20
Set point #3		1	33	21
Set point #4	1	1	42	2A
Set point #5		1	43	2B
Set point #6	1	1	52	34
Set point #7		1	53	35
Set point #8				
Set point #1				
Set point Value #1	2	4	24	18
Preact Value #1	2	4	25	19
Dead band Value #1	2	4	26	1A
Set point #2				
Set point Value #2	2	4	27	1B
Preact Value #2	2	4	28	1C
Dead band Value #2	2	4	29	1D
Set point #3				
Set point Value #3	2	4	34	22
Preact Value #3	2	4	35	23
Dead band Value #3	2	4	36	24
Set point #4				
Set point Value #4	2	4	37	25
Preact Value #4	2	4	38	26
Dead band Value #4	2	4	39	27
Set point #5				
Set point Value #5	2	4	44	2C
Preact Value #5	2	4	45	2D
Dead band Value #5	2	4	46	2E
Set point #6				
Set point Value #6	2	4	47	2F
Preact Value #6	2	4	48	30
	2	4	49	31

Section 7: Selectable Writes

Dead band Value #6				
Set point #7	2	4	54	36
Set point Value #7	2	4	55	37
Preact Value #7	2	4	56	38
Dead band Value #7				
Set point #8	2	4	57	39
Set point Value #8	2	4	58	3A
Preact Value #8	2	4	59	3B
Dead band Value #8				

 **NOTE:** The relays must be disabled by using Parameter #20 before performing a Force Relay with Parameter #19.

7.7.2 SEND TARE VALUE

Send Tare Value	# Words	# Bytes	Parameter #	Hex #
Send Tare Value	2	4	60	3C

7.7.3 SCALE CALIBRATION PARAMETERS

Use Block Write to do an actual calibration.

7.7.4 STICKER VALUE (THIS DATA IS NOT VALID FOR THE HI 2151/30WC)

Sticker Value	# Words	# Bytes	Parameter #	Hex #
Sticker Value	2	4	78	4E

7.7.5 CONFIGURATION OF RATE-OF-CHANGE

Configuration of Rate-of-Change	# Words	# Bytes	Parameter #	Hex #
Displayed Rate-of-Change time (0 = Sec, 1 = Min, 2 = Hrs)	1	2	80	50
Rate-of-Change time base evaluation period in seconds	1	2	81	51

Time base evaluation period:

0 = 1 second	5 = 6 seconds	10 = 60 seconds
1 = 2 sec.	6 = 10 sec.	11 = 120 sec.
2 = 3 sec.	7 = 12 sec.	12 = 240 sec.
3 = 4 sec.	8 = 15 sec.	13 = 450 sec.
4 = 5 sec.	9 = 360 sec.	14 = 900 sec.
		15 = 1800 sec.

HI 2151 Series Weight Controller Profibus Interface Option

7.7.6 CONFIGURATION OF ANALOG OUTPUT

Configuration of Analog Output	# Words	# Bytes	Parameter #	Hex #
Weight Parameter (Value) 0 = Gross 1 = Net 2 = Rate-of-Change 3 = Peak Hold 4 = Total Weight	0.5	1	85	55
Weight Value Represented by a Zero Scale Analog Output	2	4	86	56
Weight Value Represented by a Full Scale Analog Output	2	4	87	57

7.7.7 CONFIGURATION OF STANDARD RS232 PORT

Configuration of Standard RS 232Port	# Words	# Bytes	Parameter #	Hex #
Format of Printout	0.5	1	90	5A
Print Initiation (0 = Continuous, 1 = Altered print)*			bit 0	
Set point, Dead band and Preact			bit 1	
Rate-of-Change			bit 2	
Tare Weight			bit 3	
Net Weight			bit 4	
Gross Weight			bit 5	
Print Initiation (0 = Continuous, 1 = Altered print)			bit 6	
Reserved for future use (must be set to 0)			bit 7	
Baud Rate (0 = 600, 1 = 1200, 2 = 2400, 3 = 4800, 4 = 9600, 5 = 19200)	0.5	1	91	5B
Port Configuration (must be set to for printer output only)	0.5	1	92	5C
Stop Bits (0 = one stop bit, 1 = two stop bits)	0.5	1	93	5D
Parity (0 = none, 1 = even, 2 = odd)	0.5	1	94	5E
Handshake Control (0 = hardware, 1 = software)	0.5	1	95	5F
Word Length (0 = seven bits, 1 = eight bits)	0.5	1	96	60
Device Address (a value from 0-99)	0.5	1	97	61
Echo (0 = off, 1 = on)	0.5	1	98	62

7.7.8 WAVERSAVER & EXCITATION MONITOR (HI 2151/30WC ONLY)

WAVERSAVER and Excitation Monitor	# Words	# Bytes	Parameter #	Hex Number
WAVERSAVER (1-5)	0.5	1	99	63
Excitation Monitor	0.5	1	100	64

Section 8 Troubleshooting Procedures

8.1. SCOPE

Chapter Eight consists of all the procedures for troubleshooting the electrical, mechanical and software of the PROFIBUS Interface Card in the event of a malfunction. All the information covers the diagnosis and repair of malfunctioning components.

8.2 DISASSEMBLY AND REASSEMBLY NOTES AND CAUTIONS

- Disconnect the power cord before disassembling.
- Make sure that any disassembly is done in a clean, well ventilated, properly controlled static environment.
- Always make sure that the assemblies and sub-assemblies are well supported and insulated when doing any repairs on the PROFIBUS Interface Card or the HI 2151 Series Weight Controller.
- Place small fasteners, connectors and electrical parts in closed containers so as not to lose parts during reassembly.
- Read all the disassembly instructions before any disassembly begins. Be sure that you are familiar with the procedures. If any of the instructions for disassembly are unclear, contact **Hardy Process Solutions, Customer Support Department for additional information and assistance.**
- Do not disconnect any electrical plug, connector or terminal unless an identification tag is present or one is attached. Always note where the connector or plug was attached to the electrical component or wiring harness.
- Always install complete hardware groups (Screws, Washers, Lock Washers, Spacers, Etc.) back to the original point of removal.
- Always replace broken or damaged modules or hardware immediately!
- Always check to be sure that no loose parts are sitting on printed circuit boards or electrical connectors or wires when disassembling or reassembling.
- Always protect printed circuit boards from electrostatic discharge (ESD). Always use approved ESD wrist straps and anti-static pads when working on the PROFIBUS Interface Card.
- Always perform a final inspection after completing any reassembly to be sure that all fasteners are tight, all connectors are secure and there are no loose parts on the PROFIBUS Interface Card or other PCB Cards in the HI 2151 Series Weight Controller.
- Always follow proper safety procedures when working on or around the PROFIBUS Interface Card.

8.3 TROUBLESHOOTING GUIDE

8.3.1 LED DOES NOT COME ON (SEE FIG. 8-1)

TROUBLE	PROBABLE CAUSE	REMEDY
LED does not come on.	No power to the board.	Check powercord to see if it is plugged in or broken. Check power source to see if there is power to the outlet.

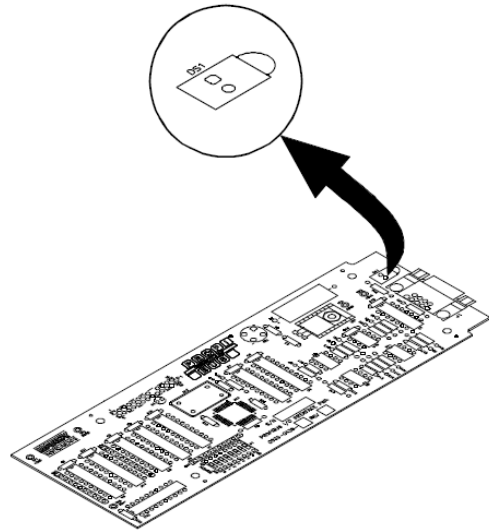

Figure 8-1

8.3.2 SELF TEST FAILS

TROUBLE	PROBABLE CAUSE	REMEDY
PLFAIL Message System failed the loop back test.	PROFIBUS PCB is plugged in incorrectly.	Remove the PROFIBUS PCB and reinstall the card being careful to be sure that the pins are not bent or in the wrong slots on the connector.
PRFAIL Message System failed the RAM test.	SPC-3 (PROFIBUS) chip has failed. NOTE: <i>Loop-back test passes but the ram test fails</i>	Replace the PROFIBUS Interface Card. Contact Hardy Process Solutions, Customer Service Department for Instructions.

8.4 ERROR CODES

See Section 4.4 for information on error code setup

List of Response/Error Codes

Unit Diag Bit #	Diagnostic Byte	Diagnostic Bit	Decimal #	Hex #	Description
N/A	1	0-7	N/A	N/A	Station Status 1*
N/A	2	0-7	N/A	N/A	Station Status 2*
N/A	3	0-7	N/A	N/A	Station Status 3*
N/A	4	0-7	N/A	N/A	Diagnostic server Address
N/A	5-6	0-7	N/A	N/A	Identification Number (=2151 hex)
N/A	7	0-7	N/A	N/A	Extended Diagnostics Length
N/A	8-13	0-7	N/A	N/A	Extended Diagnostics Data (See Below)

 NOTE:

See Profibus Standard

Unit Diag Bit #	Diagnostic Byte	Diagnostic Bit	Decimal #	Hex #	Description
1	8	1	06	06	Acknowledge good data received
2		2	21	15	Negative Acknowledge (NACK)-illegal command
3		3	49	31	Scale is in motion (e.g. unable to calibrate in motion)
4		4	50	32	Current weight sensed over scale capacity (command 70)
5		5	51	33	Weight not with zero tolerance, unable to zero
6		6	52	34	Insufficient change in weight to calibrate span (error #18)
7		7	53	35	Decimal point places must be between 0 and 4
8		8	54	36	Not a valid graduation size
9	9	1	55	37	Motion value must be greater than graduation size
10		2	56	38	Zero tolerance value must be between 0001 -999,999

**HI 2151 Series Weight Controller
Profibus Interface Option**

11		3	57	39	Acceptable number of averages between 1 and 200
12		4	58	3A	Span weight value, during calibration, must be positive
13		5	59	3B	Scale capacity value must be positive (from 1-999,999)
14		6	60	3C	Midpoint linearity value must be positive
15		7	61	3D	Rate-of-change time units must be 0, 1 or 2
16		8	62	3E	Rate-of-change time base out of range
17	10	1	65	41	Analog output not installed
18		2	66	42	Analog output request must be between 0-4
19		3	67	43	Invalid serial port (RS232) format request
20		4	68	44	Serial configuration values 0 or 1
21		5	69	45	Baud rate request out of range
22		6	70	46	Parity request out of range (must be 0, 1 or 2)
23		7	71	47	Stop bits must be 0 or 1
24		8	72	48	Word length must be 0 or 1

 NOTE: Description in the GSD file was shortened because of 32 character limit.

Unit Diag Bit #	Diagnostic Byte	Diagnostic Bit	Decimal #	Hex #	Description
25	11	1	73	49	Control (Hardware or Software) must be 0 or 1
26		2	74	4A	Device Address must be between 0-99
27		3	75	4B	Echo request must be 0 or 1
28		4	76	4C	Tare greater than scale capacity
29		5	77	4D	Blind unit option only
30		6	78	4E	Auto zero tolerance must be between .0001-999,999
31		7			Reserved for future use

32		8			Reserved for future use
33	12	1	81	51	Tare value exceeds legal range of -99,999-999,999
34		2	82	52	Units of measure are 0=Pounds/1=Kilograms
35		3			Reserved for future use
36		4	85	54	Totalizer decimal point must be equal or less than decimal point position (0-4)
37		5	85	55	C2 load cell count must be between 0-8
38		6	86	56	Sticker value must be a 6 digit number (between 65536-999999)
39		7	87	57	Analog out should be $\geq -99,999$ and $\leq 999,999$
40		8	88	58	Analog low count can't equal high count
41	13	1	89	59	Scale in Calibration Mode*
42		2	101		Invalid WAVEDSAVER
43		3			Reserved for future use
44		4	96	60	Load cell count error
45		5	97	61	No C2 [®] load cells found
46		6	98	62	Load cell capacity/sensitivity error
47		7	99	63	Load cell checksum error
48		8	100	64	Too many significant digits after the decimal to be displayed

TABLE 8-1 RESPONSE/ERROR CODES

 **NOTES:** Writes are not allowed while scale is in calibration mode.

The first 6 bytes of the diagnostic information is reserved as defined in the Profibus Standard. Bytes 7-13 are used by the HI 2151 Series -B12 PROFIBUS interface option to provide automatic response/error codes.

8.4 CLEARING PROFIBUS DIAGNOSTIC CODE ASSOCIATED BIT(S)

1. A separate bit is reserved for each response/error code. When a response/error occurs, an associated bit will be set to 1. This bit will remain set to 1 until it is cleared.
2. Clearing the error/code associated bit procedures.
 - a. Operator Selectable Transfer, rerun the Write "0" command.
 - b. Block Transfer, request the Read Block #90 via a Block Write 24 with data 90.

HI 2151 Series Weight Controller Profibus Interface Option

 NOTE: *Sending another command with valid parameters will correct the error. However, to clear the response/error code bits you must rerun the write “0” or “90” command, which clears the response/error code bits. Otherwise the error bit will always reflect the previous error.*

3. To check if the associated bit(s) have been cleared. Read the response/error bits to see if they are zero. If they are not then the associated bit(s) have not been cleared. Verify to determine if the write “0” or “90” command was correct.

8.5 PROFIBUS STATUS INDICATORS

8.5.1 PROFIBUS INTERFACE CARD LED

1. The PROFIBUS Interface Card is fitted with a “Green LED” (See Fig 8-1) with the following indicators:
 - a. A solid green light = On Line/There is communication between the PLC/PC and the PROFIBUS Interface Card.
 - b. A flashing green light = Off Line/There is no communication between the PLC/PC and the PROFIBUS Interface Card.

8.5.2 HI 2151 SERIES INDICATOR LIGHT

The status of PROFIBUS communications is determined upon entering the PROFIBUS Options Menu. (See Chapter 3) The Zero track light indicates:

1. Flashing = Run
2. Off = Off Line

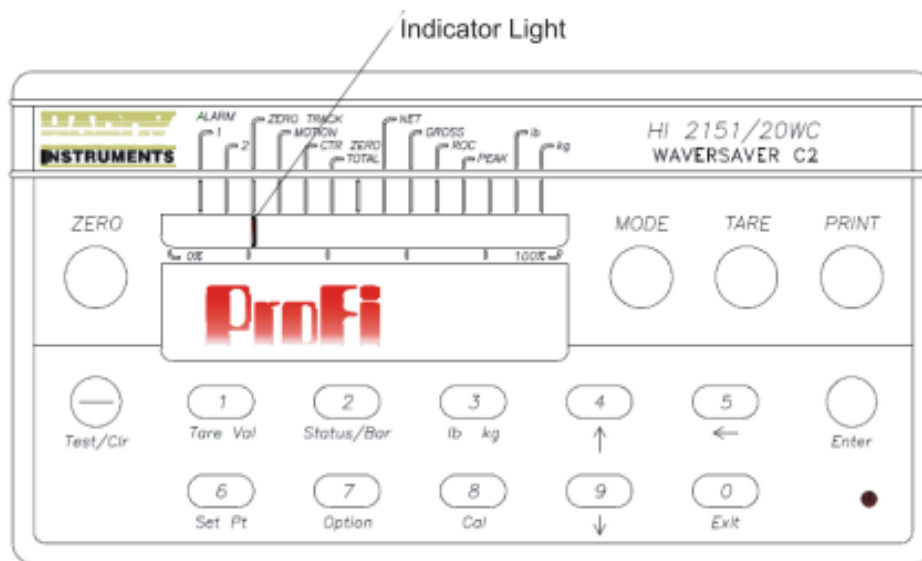

Figure 8-2

Appendix A - IEEE For Normal Float Type

IEEE Format for Normal Float Type

Used for Block Read #21 and Selectable Read Parameter #15.

Sign bit - 31

Exponent (8 bits) - 30 29 28 27 26 25 24 23

Mantissa (23 bits) - 22 21 20 19 18 17 16 15 14 13 12 11 10 9 8 7 4 5 6 3 2 1 0

Sign bit 0 = Positive value

1 = Negative value

Exponent 8 bit value - 127 (decimal) = EXPONENT VALUE

Mantissa

1 + 23 bit of mantissa (where binary point is just left of bit 22) = MANTISSA VALUE

Example:

To read NET weight, read bytes 4 through 7 in Read Data Buffer and interpret NET weight value as floating point.

<u>Sign</u>	<u>Exponent</u>	<u>Mantissa</u>
0	01111110	00000000000000000000000
+	126 - 127 = -1	$1 + 0 = 1 + (1.0 \times 2^{-1}) = 0.5$

Appendix B - Decimal, Hex, Octal, and Binary Conversion Chart

Binary	Octal	Decimal	Octal
0000	0	0	0
0001	1	1	1
0010	2	2	2
0011	3	3	3
0100	4	4	4
0101	5	5	5
0110	6	6	6
0111	7	7	7
1000	10	8	8
1001	11	9	9
1010	12	10	A
1011	13	11	B
1100	14	12	C
1101	15	13	D
1110	16	14	E
1111	17	15	F

Hexadecimal and Equivalent Numbers

